

REVISIONS				
ZONE	REV.	DESCRIPTION	DATE	APPROVED
	A	RELEASED FOR PRODUCTION	7/8/2022	DMM

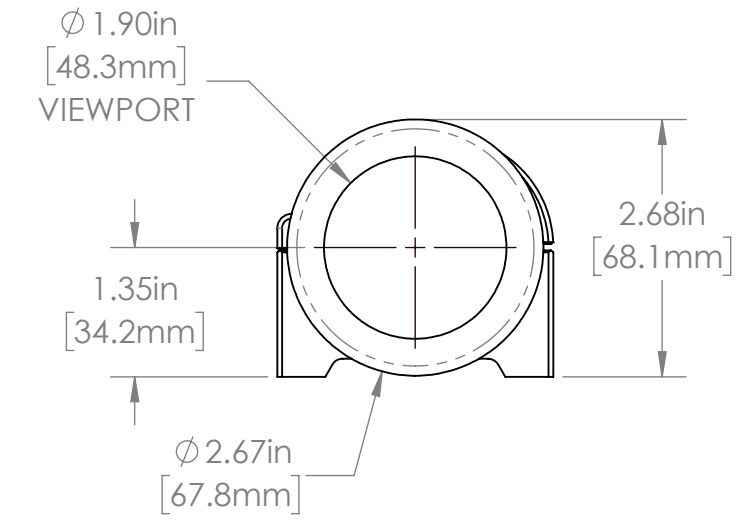
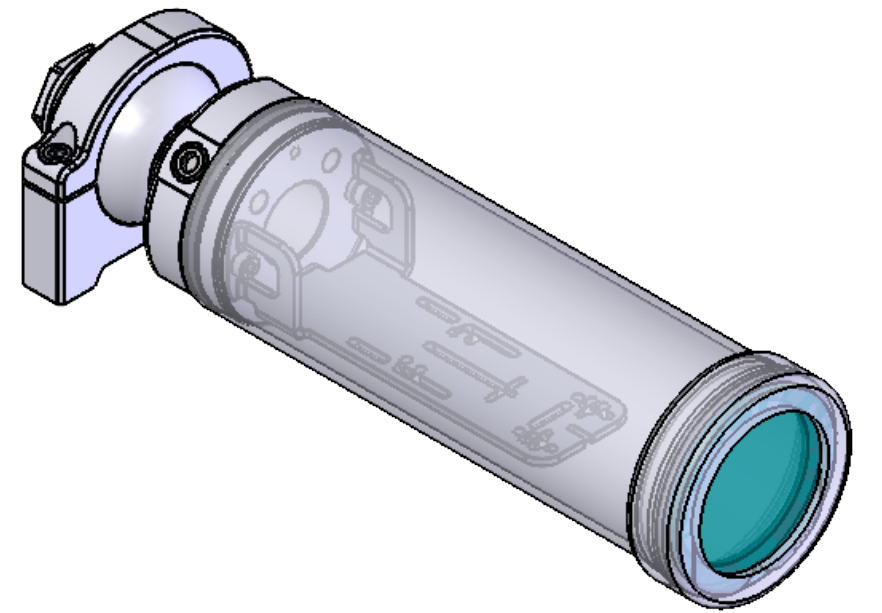

24C SERIES PROPERTIES TABLE

ENVIRONMENT RATING	IP68*	
	(*RATING MAY CHANGE IF INSTALLER MILLS CABLE GLAND OUTSIDE OF TOLERANCE)	
COMPONENT	MATERIAL	FINISH
BODY/BALL MOUNT	6061 ALUMINUM	CLEAR HARDCOAT ANODIZED
VIEWPORT	CLEAR ACRYLIC	ABR2
GASKET	VITON	NONE
ARM/ADAPTOR	304 SS	BURNISHED
HARDWARE	18-8 SS	NONE

TOLERANCES UNLESS OTHERWISE SPECIFIED

MACHINING	SHEET METAL
X.X 0.0250"	HOLE TO HOLE (SAME SURFACE) X.X 0.030"
X.XX 0.0100"	X.XX 0.010"
X.XXX 0.0050"	X.XXX 0.005"
X.XXXX 0.0005"	X.XXX 0.015"
ANGULAR 0.5°	HOLE TO FOLDED EDGE X.X 0.035"
DEBURR ALL	X.XX 0.025"
	X.XXXX 0.015"
	FOLD TO FOLD X.X 0.045"
	X.XX 0.035"
	X.XXX 0.020"
	ANGULAR 1.0°

THIS PRINT IS THE PROPERTY OF APG VISION LLC. THE INFORMATION CONTAINED HEREIN IS CONFIDENTIAL. IT IS NOT TRANSFERABLE. IT IS FURNISHED WITH THE CLEAR UNDERSTANDING THAT IT IS NOT TO BE TRACED, REPRODUCED OR USED IN ANY PROCESS OF MANUFACTURING WITHOUT WRITTEN PERMISSION FROM THE OWNER AND IS RETURNABLE UPON DEMAND. ANY INFRINGEMENT UPON THE PATENT RIGHTS SHOWN HEREIN, WHETHER IN PART OR WHOLE, WILL BE PROSECUTED.

AS PART OF OUR POLICY OF CONTINUING DEVELOPMENT, APG VISION LLC RESERVES THE RIGHT TO ALTER SPECIFICATIONS WITHOUT PRIOR NOTICE.

APG Vision LLC
4055 Alpha Drive
Allison Park, PA 15101 USA
Phone +1 (412) 487-8211
apgvision.com

apgvision

DESCRIPTION:
24C 7IN BARREL, UNIVERSAL ARM, ACRYLIC VP, BALL MOUNT

MATERIAL: SEE BOM

FINISH: SEE BOM

DRAWN BY: DMM	DATE: 7/8/2022	SCALE: 1:2	SHT-SIZE: B	APPROX. WEIGHT (LBS): 1.6789
CHECKED BY: DMM	DATE: 7/8/2022	PART NUMBER: 24C-DU		REVISION: A

Sheet 1 of 1