

SECTION A-A

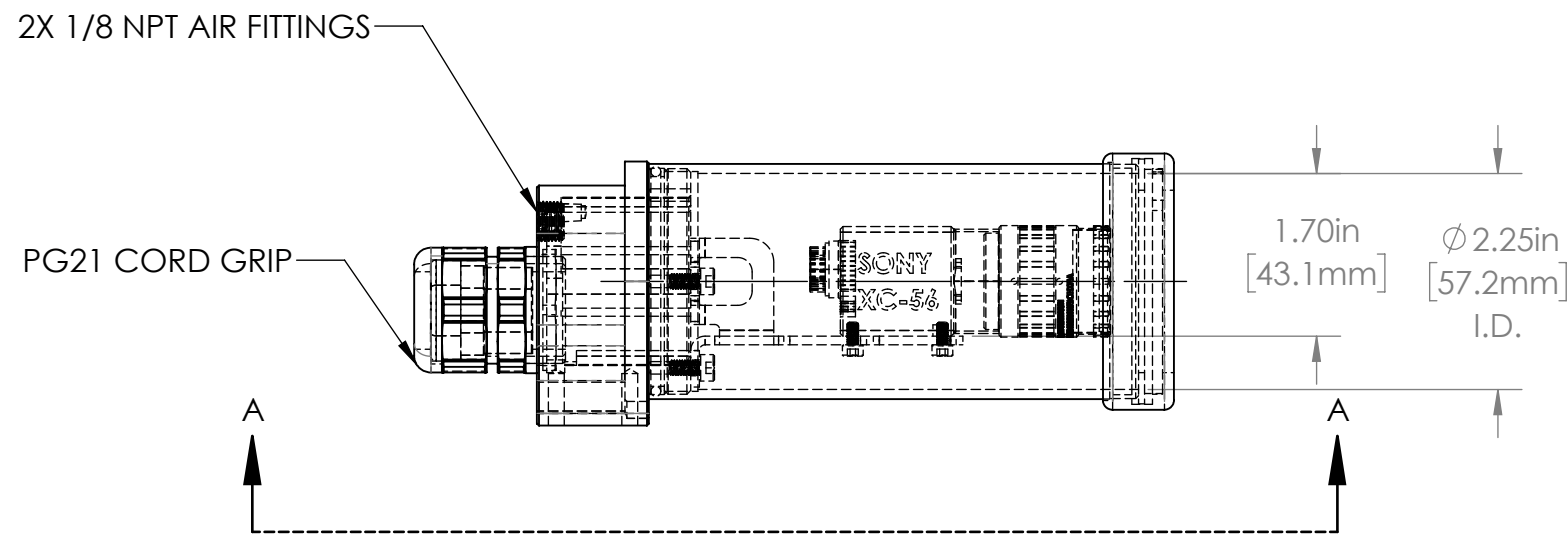

REVISIONS				
ZONE	REV.	DESCRIPTION	DATE	APPROVED
	A	RELEASED FOR PRODUCTION	4/18/2022	DMM

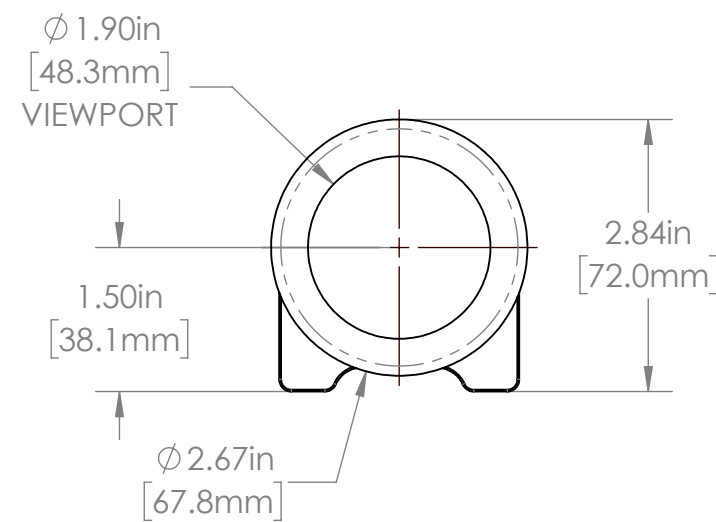
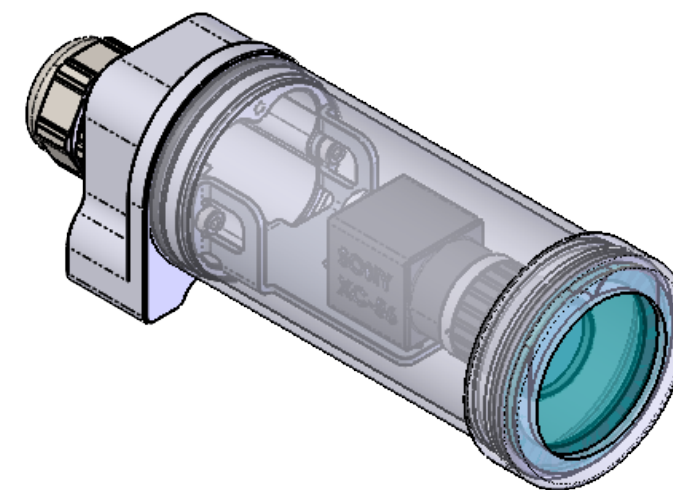

24C SERIES PROPERTIES TABLE

ENVIRONMENT RATING	IP68*	
	(*RATING MAY CHANGE IF INSTALLER MILLS CABLE GLAND OUTSIDE OF TOLERANCE)	
COMPONENT	MATERIAL	FINISH
BODY/BARREL/ FACEPLATE	6061 ALUMINUM	CLEAR HARDCOAT ANODIZED
VIEWPORT	SODA LIME GLASS	NONE
GASKET	VITON	NONE
ARM	304 SS	BURNISHED
ADAPTER	6061 ALUMINUM	NONE
HARDWARE	18-8 SS	NONE

TOLERANCES UNLESS OTHERWISE SPECIFIED

MACHINING		SHEET METAL	
X.X	0.0250"	HOLE TO HOLE (SAME SURFACE)	
X.XX	0.0100"	X.X	0.030"
X.XXX	0.0050"	X.XX	0.010"
X.XXXX	0.0005"	X.XXX	0.005"
ANGULAR	0.5°	HOLE TO FOLDED EDGE	
DEBURR ALL		X.X	0.035"
		X.XX	0.025"
		X.XXX	0.015"
		FOLD TO FOLD	
		X.X	0.045"
		X.XX	0.035"
		X.XXX	0.020"
		ANGULAR 1.0°	

THIS PRINT IS THE PROPERTY OF APG VISION LLC. THE INFORMATION CONTAINED HEREIN IS CONFIDENTIAL. IT IS NOT TRANSFERABLE. IT IS FURNISHED WITH THE CLEAR UNDERSTANDING THAT IT IS NOT TO BE TRACED, REPRODUCED OR USED IN ANY PROCESS OF MANUFACTURING WITHOUT WRITTEN PERMISSION FROM THE OWNER AND IS RETURNABLE UPON DEMAND. ANY INFRINGEMENT UPON THE PATENT RIGHTS SHOWN HEREIN, WHETHER IN PART OR WHOLE, WILL BE PROSECUTED.

AS PART OF OUR POLICY OF CONTINUING DEVELOPMENT, APG VISION LLC RESERVES THE RIGHT TO ALTER SPECIFICATIONS WITHOUT PRIOR NOTICE.

APG Vision LLC 4055 Alpha Drive Allison Park, PA 15101 USA Phone +1 (412) 487-8211 apgvision.com				
apgvision				
DESCRIPTION: 24C 5.1IN BARREL, 20mm O.C. SLOTTED ARM, ACRYLIC VP				
MATERIAL: SEE BOM				
FINISH: SEE BOM				
DRAWN BY: DMM	DATE: 4/18/2022	SCALE: 1:2	SHT-SIZE: B	APPROX. WEIGHT (LBS) 1.1617
CHECKED BY: DMM	DATE: 4/18/2022	PART NUMBER: 24C-EI		REVISION A
Sheet 1 of 1				