

REVISIONS				
ZONE	REV.	DESCRIPTION	DATE	APPROVED
	A	RELEASED FOR PRODUCTION	4/19/2022	DMM

A

B

C

D

A

B

C

D

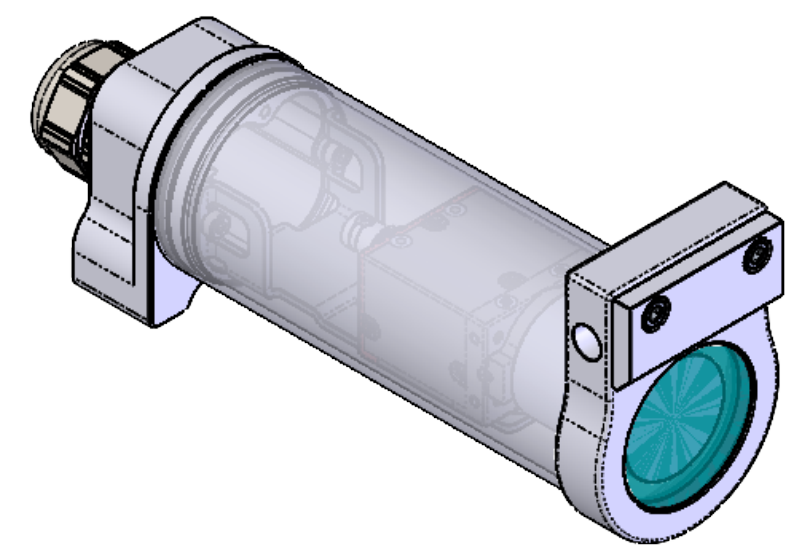
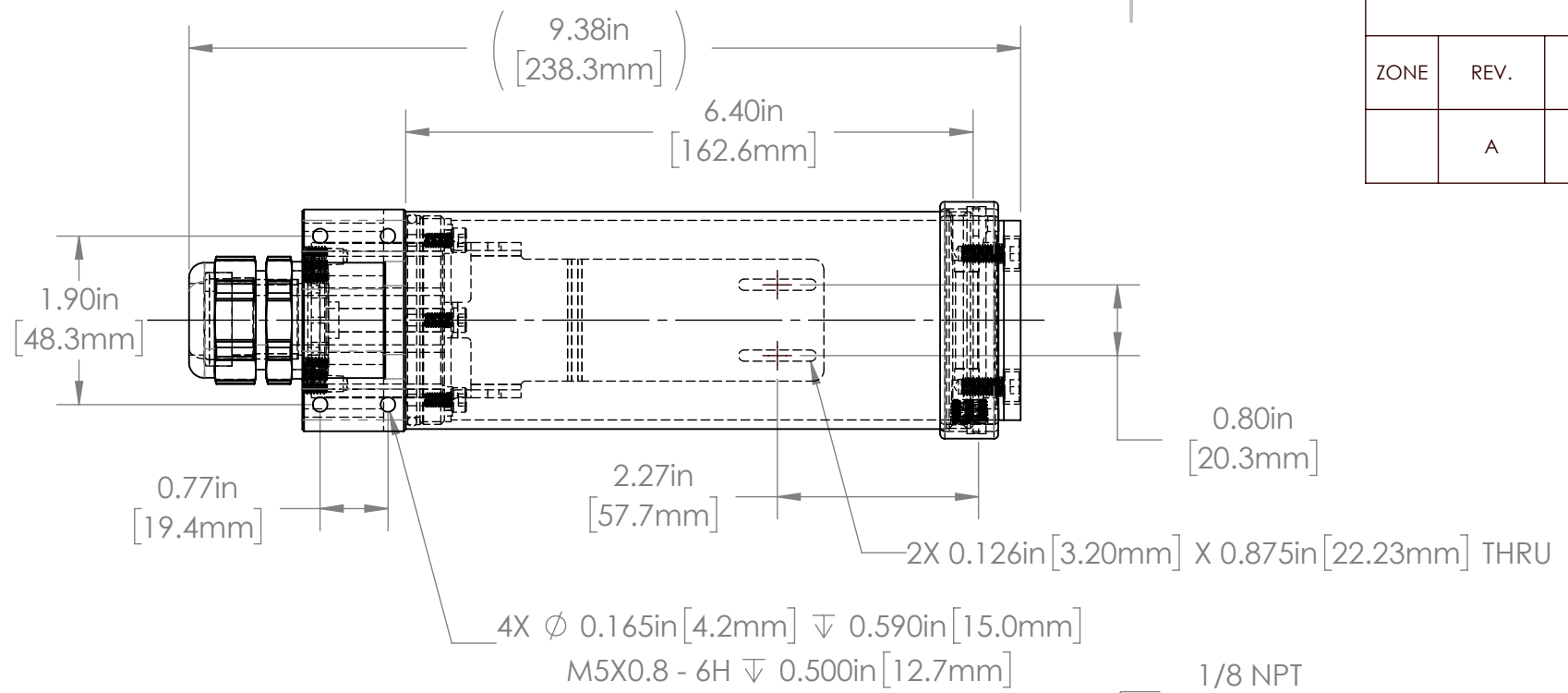

2X 1/8 NPT AIR FITTINGS

PG21 CORD GRIP

SECTION A-A

1/8 NPT BOTH SIDES

AIR SHIELD

1.70in [43.1mm] Ø 2.25in [57.2mm] I.D.

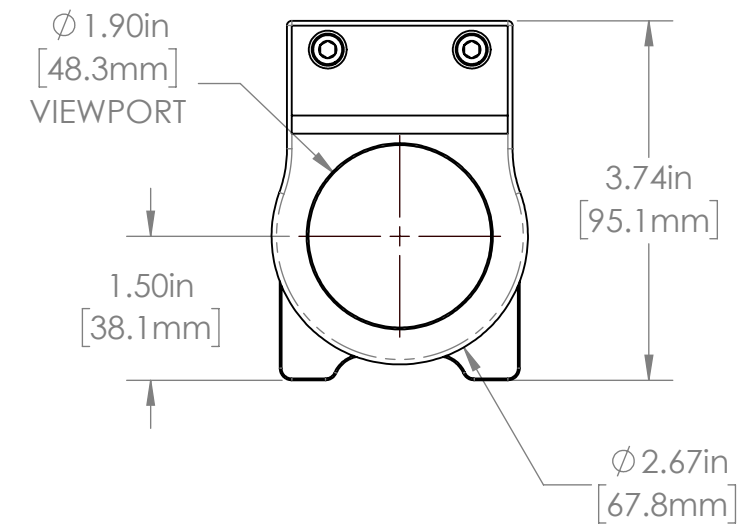

24C SERIES PROPERTIES TABLE

ENVIRONMENT RATING	IP68*	
	(*RATING MAY CHANGE IF INSTALLER MILLS CABLE GLAND OUTSIDE OF TOLERANCE)	
COMPONENT	MATERIAL	FINISH
BODY/BARREL/FACEPLATE	6061 ALUMINUM	CLEAR HARDCOAT ANODIZED
VIEWPORT	BOROSILICATE GLASS	NONE
GASKET	VITON	NONE
ARM/ADAPTER	304 SS	BURNISHED
HARDWARE	18-8 SS	NONE

TOLERANCES UNLESS OTHERWISE SPECIFIED

MACHINING	SHEET METAL
X.X 0.0250"	HOLE TO HOLE (SAME SURFACE) X.X 0.030"
X.XX 0.0100"	X.XX 0.010"
X.XXX 0.0050"	X.XXX 0.005"
X.XXXX 0.0005"	X.XXX 0.015"
ANGULAR 0.5°	HOLE TO FOLDED EDGE X.X 0.035"
DEBURR ALL	X.XX 0.025"
	X.XXX 0.015"
	FOLD TO FOLD X.X 0.045"
	X.XX 0.035"
	X.XXX 0.020"
	ANGULAR 1.0°

THIS PRINT IS THE PROPERTY OF APG VISION LLC. THE INFORMATION CONTAINED HEREIN IS CONFIDENTIAL. IT IS NOT TRANSFERABLE. IT IS FURNISHED WITH THE CLEAR UNDERSTANDING THAT IT IS NOT TO BE TRACED, REPRODUCED OR USED IN ANY PROCESS OF MANUFACTURING WITHOUT WRITTEN PERMISSION FROM THE OWNER AND IS RETURNABLE UPON DEMAND. ANY INFRINGEMENT UPON THE PATENT RIGHTS SHOWN HEREIN, WHETHER IN PART OR WHOLE, WILL BE PROSECUTED.

AS PART OF OUR POLICY OF CONTINUING DEVELOPMENT, APG VISION LLC RESERVES THE RIGHT TO ALTER SPECIFICATIONS WITHOUT PRIOR NOTICE.

APG Vision LLC
4055 Alpha Drive
Allison Park, PA 15101 USA
Phone +1 (412) 487-8211
apgvision.com

apgvision

DESCRIPTION:
24C 6.4IN BARREL, 20.3mm O.C. ARM, BORO VP

MATERIAL: SEE BOM

FINISH: SEE BOM

DRAWN BY: DMM	DATE: 4/19/2022	SCALE: 1:2	SHT-SIZE: B	APPROX. WEIGHT (LBS): 1.5961
CHECKED BY: DMM	DATE: 4/19/2022	PART NUMBER: 24C-EJ	REVISION: A	

Sheet 1 of 1