

| REVISIONS | | | | |
|-----------|------|-------------------------|-----------|----------|
| ZONE | REV. | DESCRIPTION | DATE | APPROVED |
| | A | RELEASED FOR PRODUCTION | 9/15/2023 | DMM |

A

B

C

D

A

B

C

D

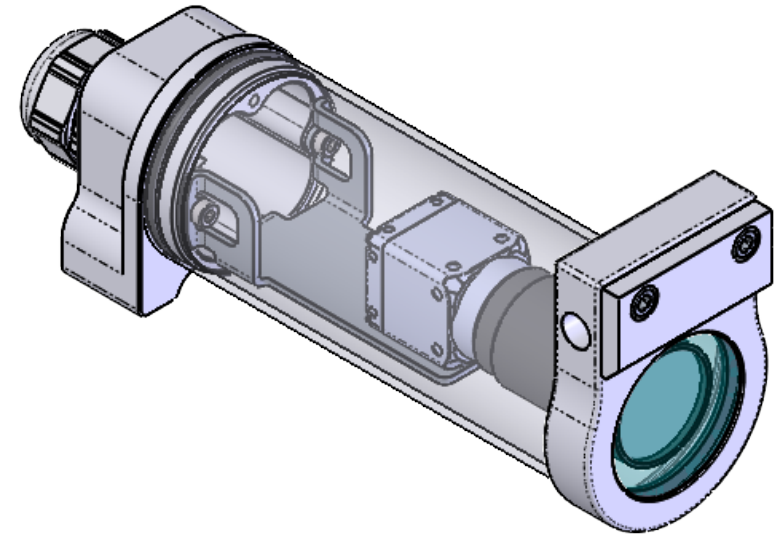
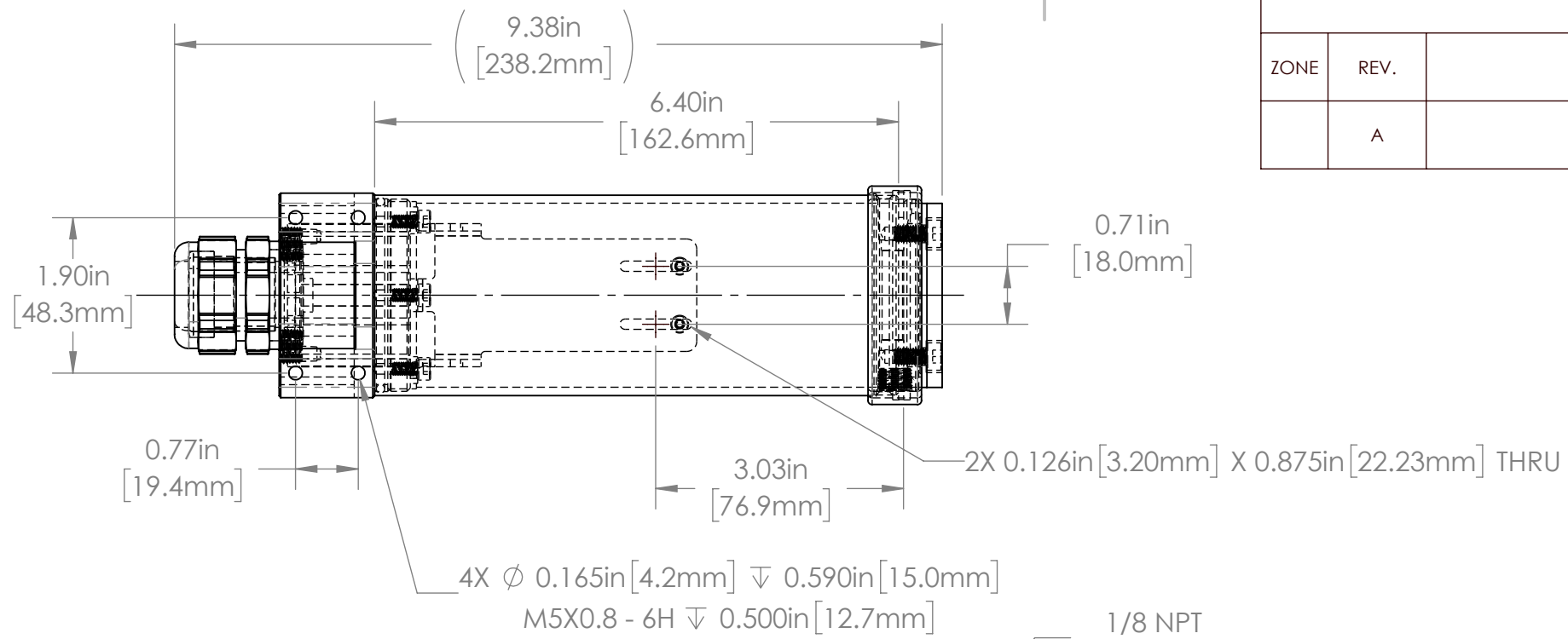

2X 1/8 NPT AIR FITTINGS

PG21 CORD GRIP

SECTION A-A

1/8 NPT BOTH SIDES

AIR SHIELD

1.70in [43.1mm] Ø 2.25in [57.2mm] I.D.

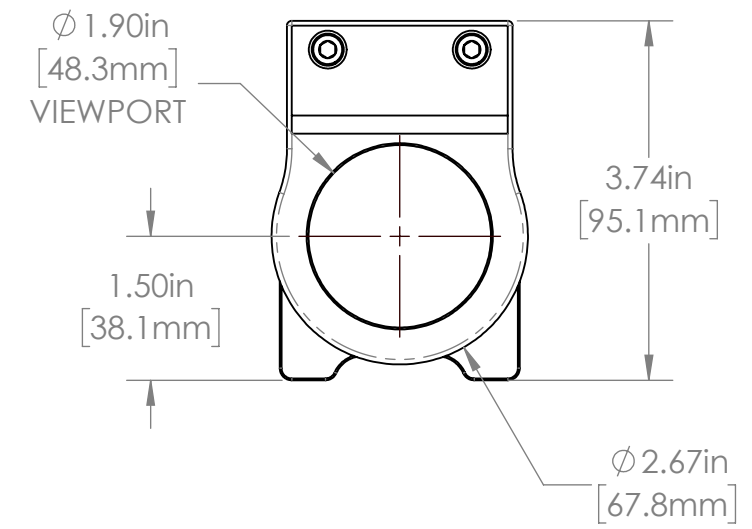

24C SERIES PROPERTIES TABLE

| | | |
|--|--|------------------------------------|
| ENVIRONMENT RATING | IP68* | |
| | (*RATING MAY CHANGE IF INSTALLER MILLS CABLE GLAND OUTSIDE OF TOLERANCE) | |
| COMPONENT | MATERIAL | FINISH |
| BODY/BARREL/ AIR SHIELD VIEWPORT | 6061 ALUMINUM SODA LIME GLASS | CLEAR HARDCOAT ANODIZED NONE |
| GASKET | VITON | NONE |
| ARM/ADAPTER | 304 SS | BURNISHED |
| HARDWARE | 18-8 SS | NONE |

| TOLERANCES UNLESS OTHERWISE SPECIFIED | | |
|---------------------------------------|-----------------------------|--|
| MACHINING | SHEET METAL | |
| X.X 0.0250" | HOLE TO HOLE (SAME SURFACE) | |
| X.XX 0.0100" | X.X 0.030" | |
| X.XXX 0.0050" | X.XX 0.010" | |
| X.XXXX 0.0005" | X.XXX 0.005" | |
| ANGULAR 0.5° | HOLE TO FOLDED EDGE | |
| DEBURR ALL | X.X 0.035" | |
| | X.XX 0.025" | |
| | X.XXX 0.015" | |
| | FOLD TO FOLD | |
| | X.X 0.045" | |
| | X.XX 0.035" | |
| | X.XXX 0.020" | |
| | ANGULAR 1.0° | |

APG Vision LLC
4055 Alpha Drive
Allison Park, PA 15101 USA
Phone +1 (412) 487-8211
apgvision.com

apgvision

DESCRIPTION:
**24C 6.4IN BARREL, GLASS VIEWPORT,
18mm O.C. ARM, AIR SHIELD**

MATERIAL: **SEE BOM**

FINISH: **SEE BOM**

| | | | | |
|--------------------|--------------------|-------------------------------|----------------|---------------------------------|
| DRAWN BY: DMM | DATE: 9/15/2023 | SCALE: 1:2 | SHT-SIZE: B | APPROX. WEIGHT (LBS): 1.5762 |
| CHECKED BY: DMM | DATE: 9/15/2023 | PART NUMBER: 24C-ES | | REVISION: A |

Sheet 1 of 1