

1 2 3 4 5 6

A

B

C

D

A

B

C

D

REVISIONS				
ZONE	REV.	DESCRIPTION	DATE	APPROVED
	A	RELEASED FOR PRODUCTION	11/22/2022	DMM

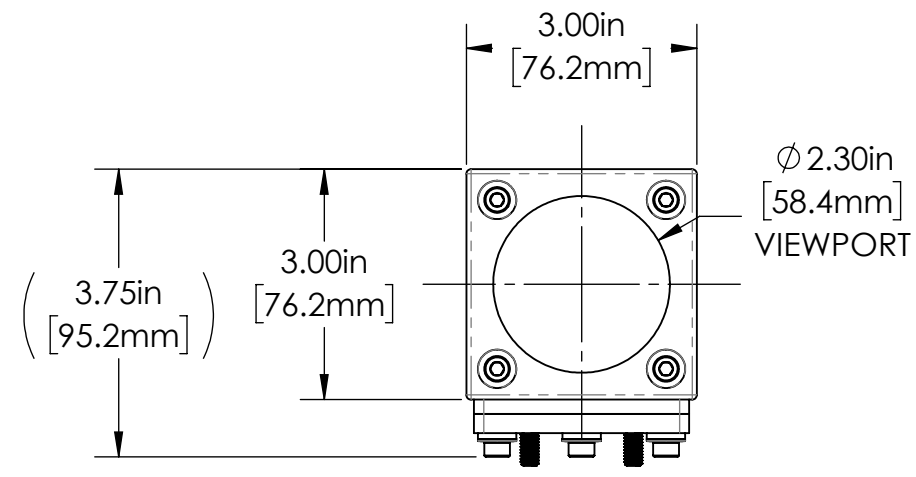
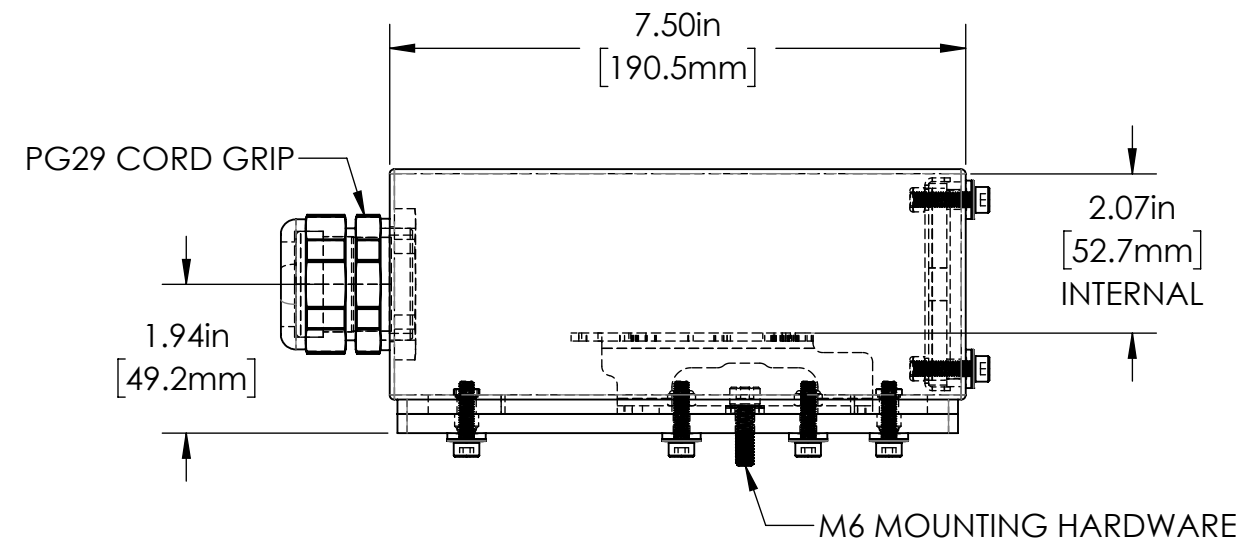
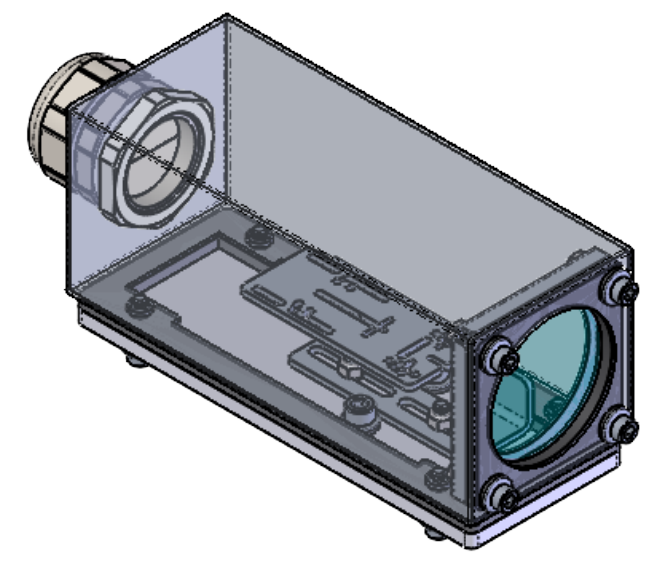
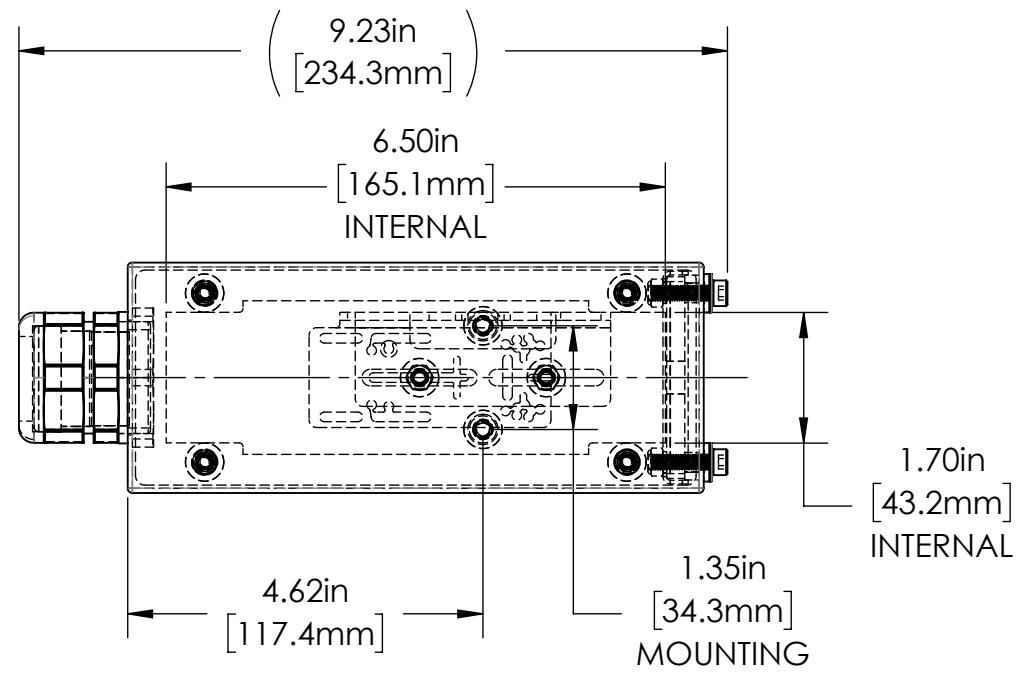

30D SERIES PROPERTIES TABLE

ENVIRONMENT RATING	IP64*	
	(*RATING MAY CHANGE IF INSTALLER MILLS CABLE GLAND OUTSIDE OF TOLERANCE)	
COMPONENT	MATERIAL	FINISH
BODY	304 SS	BURNISHED
BASE	6061 ALUMINUM	CLEAR HARDCOAT ANODIZED
VIEWPORT	CLEAR ACRYLIC	ABR2
GASKET	EPDM FOAM	NONE
ARM/ADAPTER	304 SS	NONE
HARDWARE	18-8 SS	NONE

TOLERANCES UNLESS OTHERWISE SPECIFIED

MACHINING		SHEET METAL	
X.X	0.0250"	HOLE TO HOLE (SAME SURFACE)	
X.XX	0.0100"	X.X	0.030"
X.XXX	0.0050"	X.XX	0.010"
X.XXXX	0.0005"	X.XXX	0.005"
ANGULAR	0.5°	HOLE TO FOLDED EDGE	
DEBURR ALL		X.X	0.035"
		X.XX	0.025"
		X.XXX	0.015"
		FOLD TO FOLD	
		X.X	0.045"
		X.XX	0.035"
		X.XXX	0.020"
		ANGULAR 1.0°	

THIS PRINT IS THE PROPERTY OF APG VISION LLC. THE INFORMATION CONTAINED HEREIN IS CONFIDENTIAL. IT IS NOT TRANSFERABLE. IT IS FURNISHED WITH THE CLEAR UNDERSTANDING THAT IT IS NOT TO BE TRACED, REPRODUCED OR USED IN ANY PROCESS OF MANUFACTURING WITHOUT WRITTEN PERMISSION FROM THE OWNER AND IS RETURNABLE UPON DEMAND. ANY INFRINGEMENT UPON THE PATENT RIGHTS SHOWN HEREIN, WHETHER IN PART OR WHOLE, WILL BE PROSECUTED.

AS PART OF OUR POLICY OF CONTINUING DEVELOPMENT, APG VISION LLC RESERVES THE RIGHT TO ALTER SPECIFICATIONS WITHOUT PRIOR NOTICE.

APG Vision LLC 4055 Alpha Drive Allison Park, PA 15101 USA Phone +1 (412) 487-8211 apgvision.com				
DESCRIPTION: 30D 7.5IN BODY WITH PG29 CORD GRIP, ACRYLIC VIEWPORT, UNIVERSAL ARM				
MATERIAL:		SEE BOM		
FINISH:		SEE BOM		
DRAWN BY:	DATE:	SCALE:	SHT-SIZE:	APPROX. WEIGHT (LBS)
GAS	11/22/2022	2:5	B	2.6888
CHECKED BY:	DATE:	PART NUMBER:		REVISION
DMM	11/22/2022	30D-EB		A
Sheet 1 of 1				

1 2 3 4 5 6