

REVISIONS				
ZONE	REV.	DESCRIPTION	DATE	APPROVED
	A	RELEASED FOR PRODUCTION	12/6/2021	DMM
2-C3	B	ADD BRONZE SILENCER CONE AND 90 ELBOW	12/17/2021	DMM

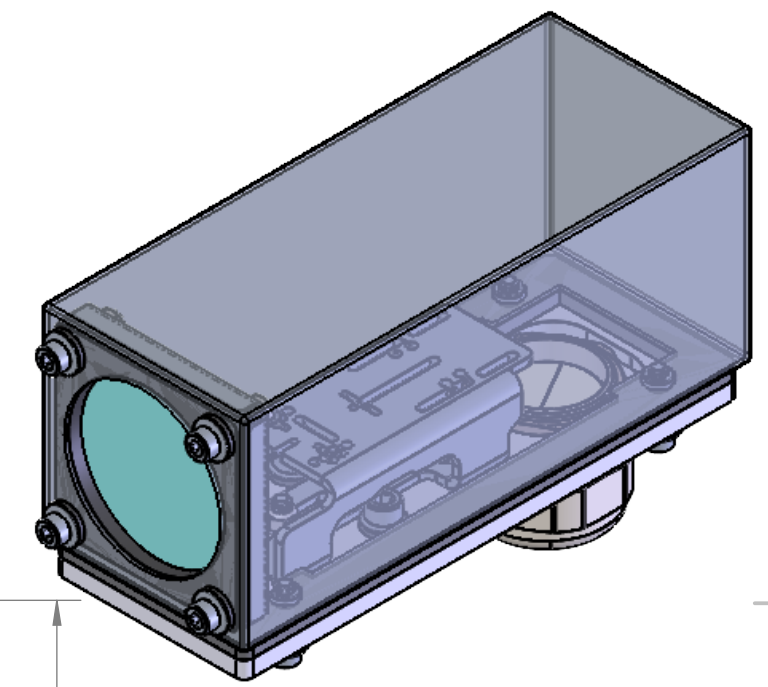

### 30D SERIES PROPERTIES TABLE

<b>ENVIRONMENT RATING</b>	IP64*	
	(*RATING MAY CHANGE IF INSTALLER MILLS CABLE GLAND OUTSIDE OF TOLERANCE)	
<b>COMPONENT</b>	<b>MATERIAL</b>	<b>FINISH</b>
BODY	304 SS	BURNISHED
BASE	6061 ALUMINUM	CLEAR HARDCOAT ANODIZED
VIEWPORT	GLASS	AS SUPPLIED
GASKET	EPDM FOAM	NONE
ARM/ADAPTOR	304 SS	BARE
HARDWARE	18-8 SS	NONE

TOLERANCES UNLESS OTHERWISE SPECIFIED

MACHINING		SHEET METAL	
X.X	0.0250"	HOLE TO HOLE (SAME SURFACE)	
X.XX	0.0100"	X.X	0.030"
X.XXX	0.0050"	X.XX	0.010"
X.XXXX	0.0005"	X.XXX	0.005"
ANGULAR	0.5°	HOLE TO FOLDED EDGE	
DEBURR ALL		X.X	0.035"
		X.XX	0.025"
		X.XXX	0.015"
		FOLD TO FOLD	
		X.X	0.045"
		X.XX	0.035"
		X.XXX	0.020"
		ANGULAR 1.0°	

THIS PRINT IS THE PROPERTY OF APG VISION LLC. THE INFORMATION CONTAINED HEREIN IS CONFIDENTIAL. IT IS NOT TRANSFERABLE. IT IS FURNISHED WITH THE CLEAR UNDERSTANDING THAT IT IS NOT TO BE TRACED, REPRODUCED OR USED IN ANY PROCESS OF MANUFACTURING WITHOUT WRITTEN PERMISSION FROM THE OWNER AND IS RETURNABLE UPON DEMAND. ANY INFRINGEMENT UPON THE PATENT RIGHTS SHOWN HEREIN, WHETHER IN PART OR WHOLE, WILL BE PROSECUTED.

AS PART OF OUR POLICY OF CONTINUING DEVELOPMENT, APG VISION LLC RESERVES THE RIGHT TO ALTER SPECIFICATIONS WITHOUT PRIOR NOTICE.

APG Vision LLC  
4055 Alpha Drive  
Allison Park, PA 15101 USA  
Phone +1 (412) 487-8211  
apgvision.com

**apgvision**

DESCRIPTION:  
**30D 7.5IN SEALED ENCLOSURE, AIR-COOLED, UNIVERSAL ARM**

MATERIAL:  
**SEE PROPERTIES TABLE**

FINISH:  
**SEE PROPERTIES TABLE**

DRAWN BY: TWD	DATE: 12/6/2021	SCALE: 1:2	SHT-SIZE: B	APPROX. WEIGHT (LBS): 2.8287
CHECKED BY: DMM	DATE: 12/17/2021	PART NUMBER: <b>30D-GE</b>		REVISION: B

Sheet 1 of 2

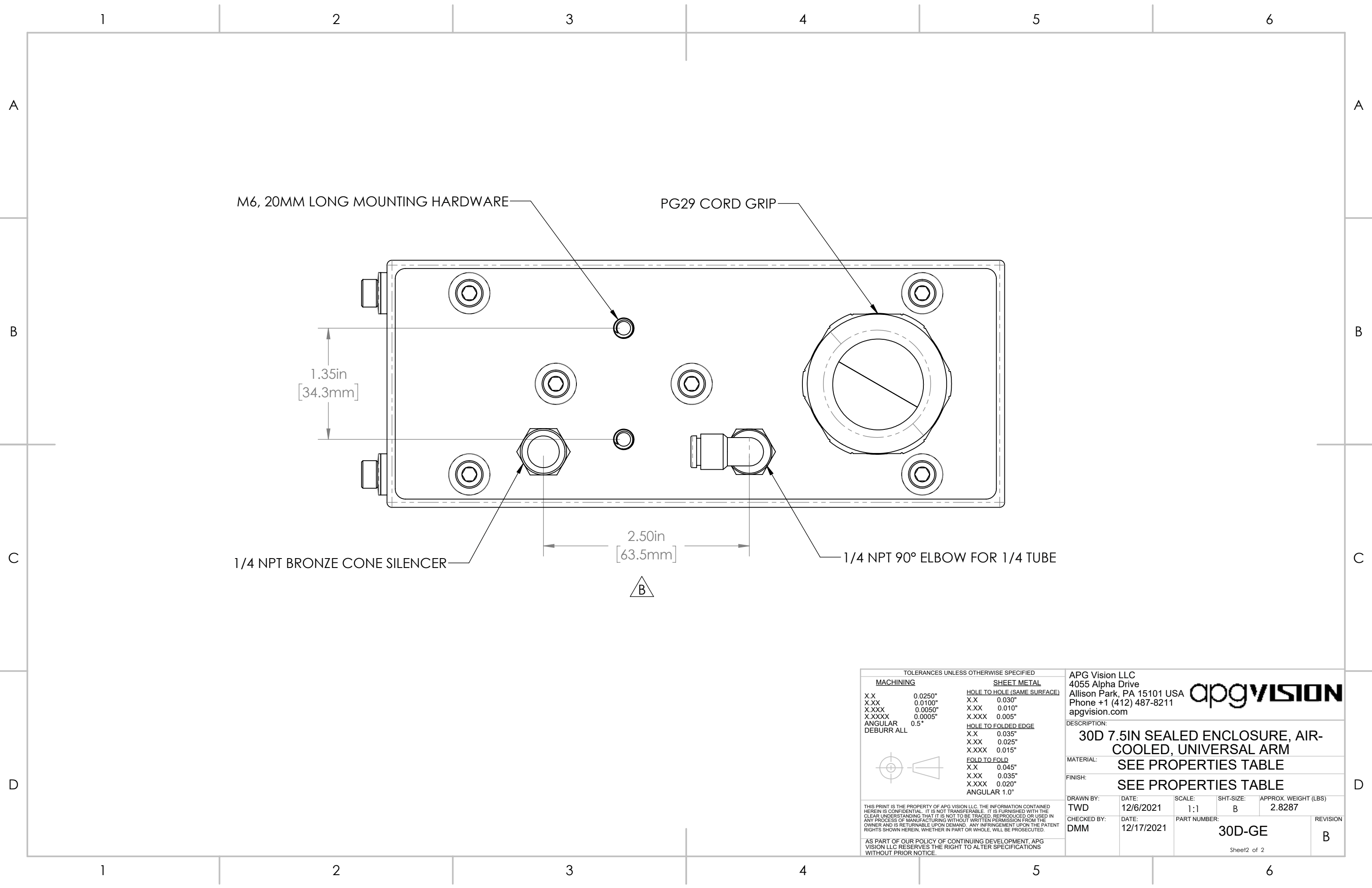

TOLERANCES UNLESS OTHERWISE SPECIFIED

MACHINING		SHEET METAL	
X.X	0.0250"	HOLE TO HOLE (SAME SURFACE)	
X.XX	0.0100"	X.X	0.030"
X.XXX	0.0050"	X.XX	0.010"
X.XXXX	0.0005"	X.XXX	0.005"
ANGULAR	0.5°	HOLE TO FOLDED EDGE	
DEBURR ALL		X.X	0.035"
		X.XX	0.025"
		X.XXX	0.015"
		FOLD TO FOLD	
		X.X	0.045"
		X.XX	0.035"
		X.XXX	0.020"
			ANGULAR 1.0°

THIS PRINT IS THE PROPERTY OF APG VISION LLC. THE INFORMATION CONTAINED HEREIN IS CONFIDENTIAL. IT IS NOT TRANSFERABLE. IT IS FURNISHED WITH THE CLEAR UNDERSTANDING THAT IT IS NOT TO BE TRACED, REPRODUCED OR USED IN ANY PROCESS OF MANUFACTURING WITHOUT WRITTEN PERMISSION FROM THE OWNER AND IS RETURNABLE UPON DEMAND. ANY INFRINGEMENT UPON THE PATENT RIGHTS SHOWN HEREIN, WHETHER IN PART OR WHOLE, WILL BE PROSECUTED.

AS PART OF OUR POLICY OF CONTINUING DEVELOPMENT, APG VISION LLC RESERVES THE RIGHT TO ALTER SPECIFICATIONS WITHOUT PRIOR NOTICE.

APG Vision LLC  
4055 Alpha Drive  
Allison Park, PA 15101 USA  
Phone +1 (412) 487-8211  
apgvision.com

**apgvision**

DESCRIPTION:  
**30D 7.5IN SEALED ENCLOSURE, AIR-COOLED, UNIVERSAL ARM**

MATERIAL:  
**SEE PROPERTIES TABLE**

FINISH:  
**SEE PROPERTIES TABLE**

DRAWN BY: TWD	DATE: 12/6/2021	SCALE: 1:1	SHT-SIZE: B	APPROX. WEIGHT (LBS): 2.8287
CHECKED BY: DMM	DATE: 12/17/2021	PART NUMBER: <b>30D-GE</b>		REVISION: <b>B</b>

Sheet2 of 2