

1 2 3 4 5 6

A A

B B

C C

D D

REVISIONS				
ZONE	REV.	DESCRIPTION	DATE	APPROVED
	A	RELEASED FOR PRODUCTION	7/22/2022	DMM

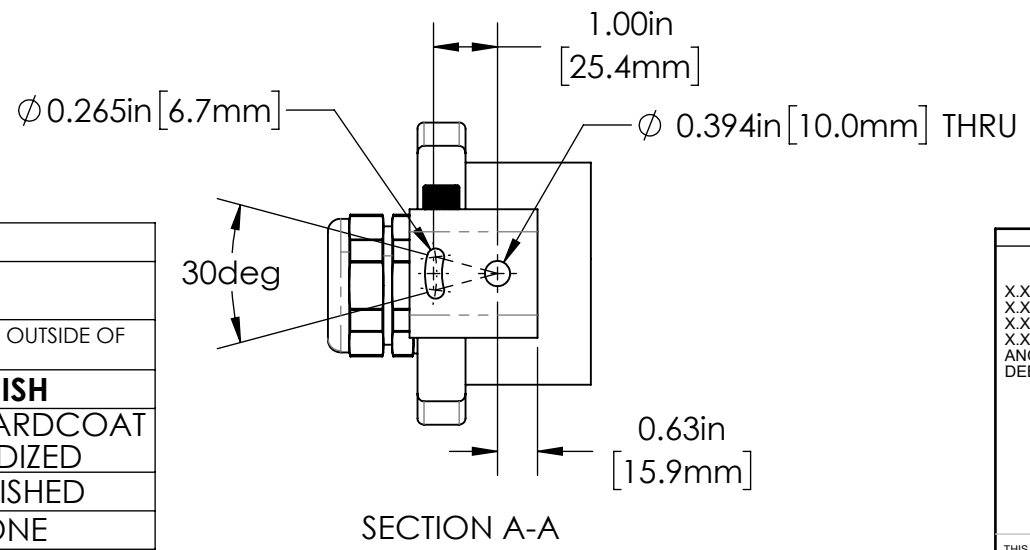
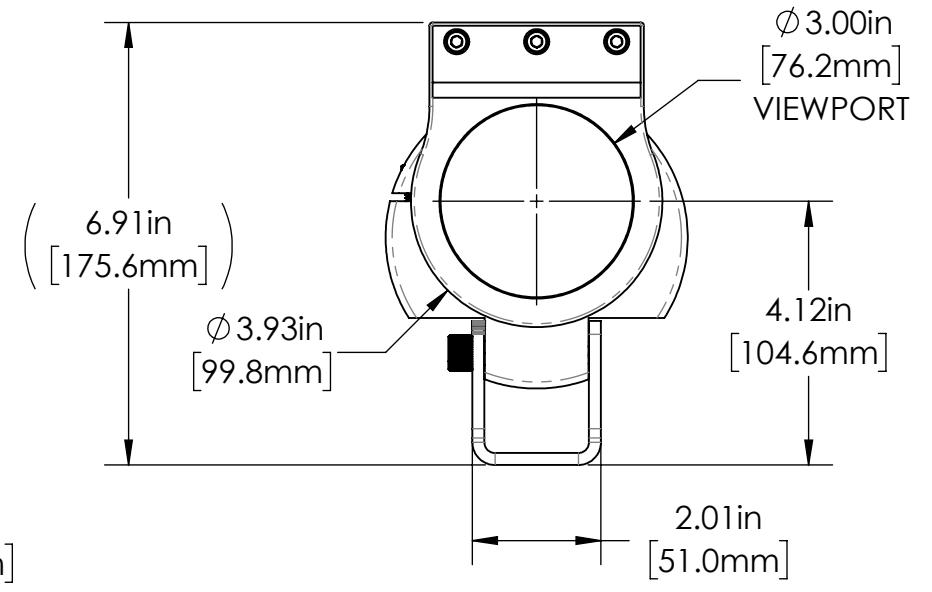
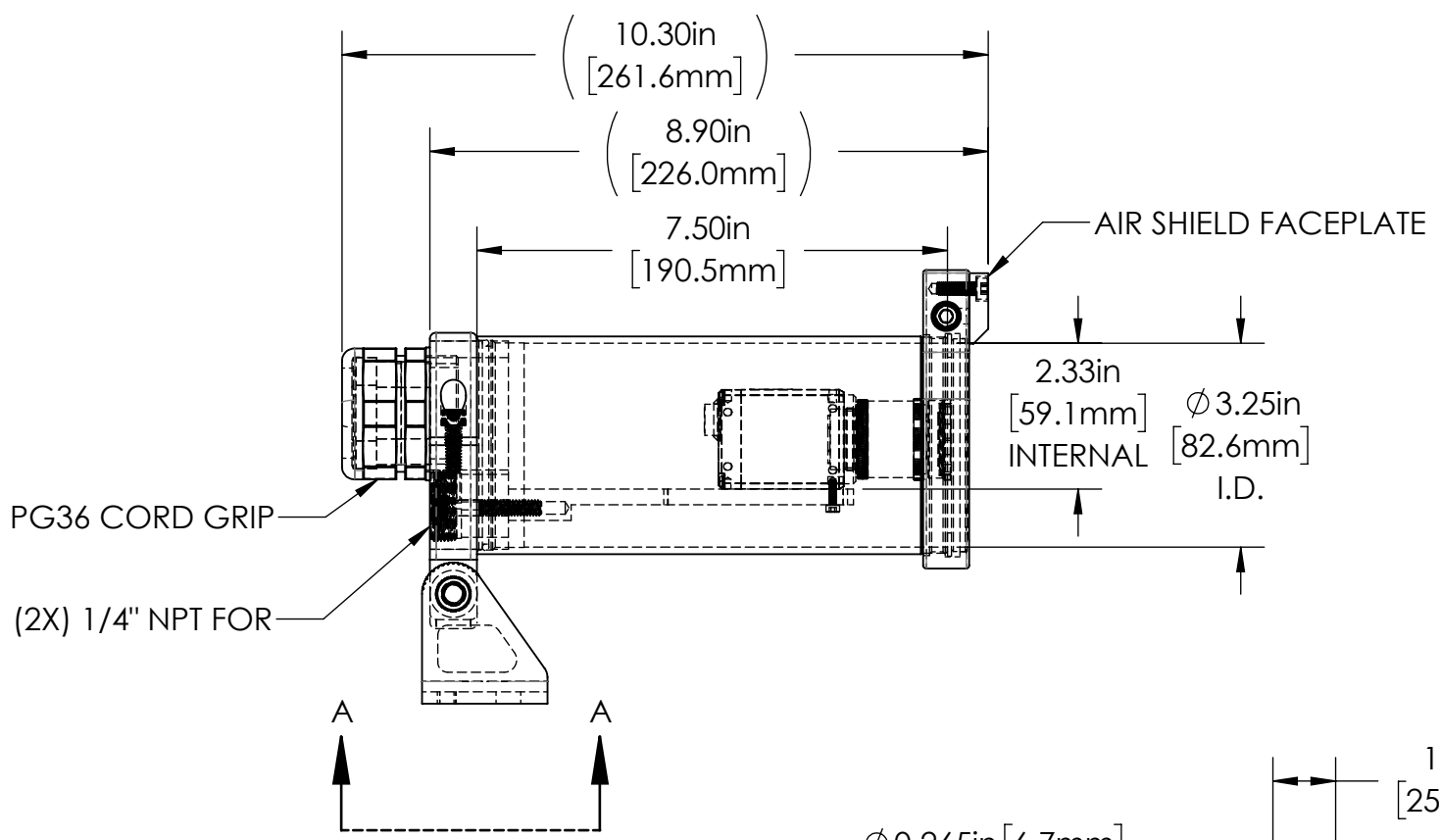
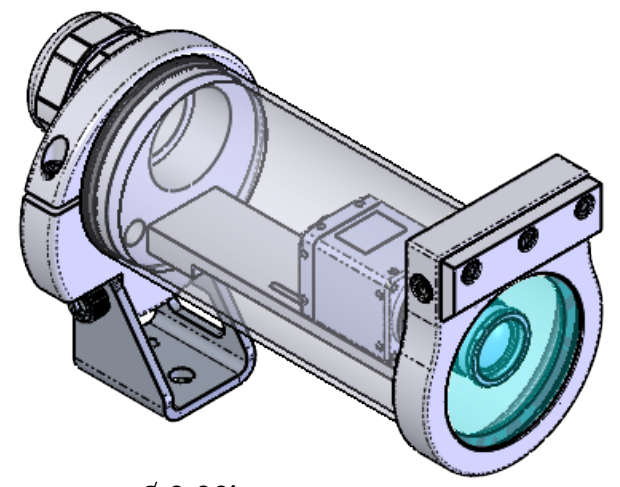
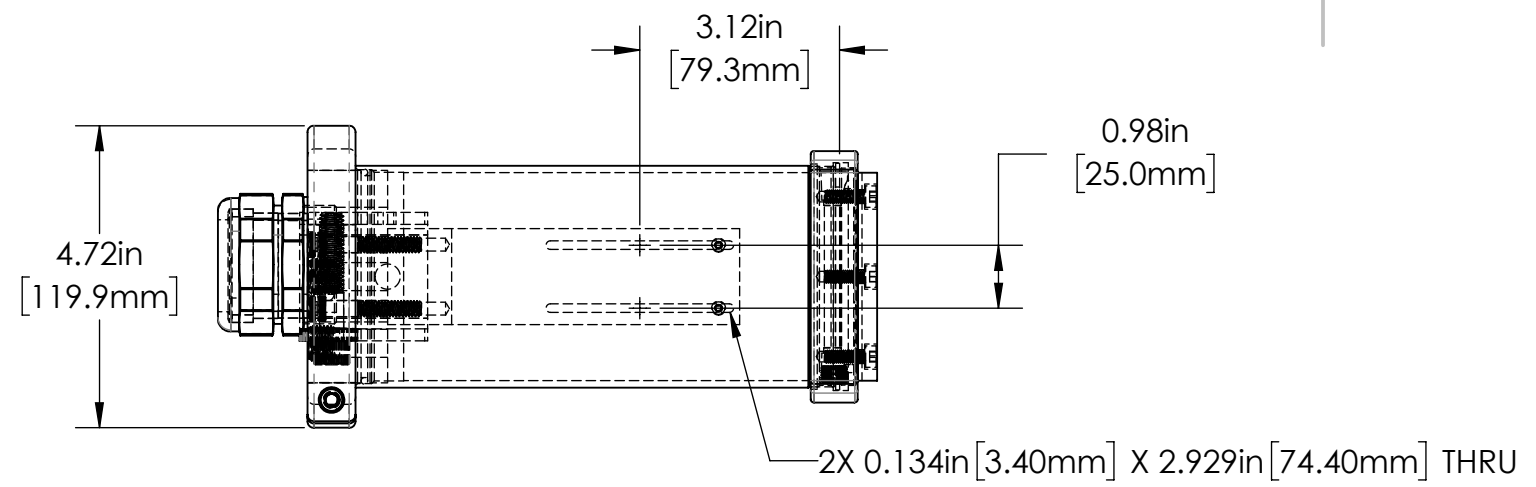

35C SERIES PROPERTIES TABLE

ENVIRONMENT RATING	IP68*	
	(*RATING MAY CHANGE IF INSTALLER MILLS CABLE GLAND OUTSIDE OF TOLERANCE)	
COMPONENT	MATERIAL	FINISH
BODY/BASE/ BARREL/FACEPLATE	6061 ALUMINUM	CLEAR HARDCOAT ANODIZED
FOOT	304 SS	BURNISHED
VIEWPORT	SODA LIME GLASS	NONE
GASKET	VITON	NONE
ARM/ADAPTER	6061 ALUMINUM	NONE
HARDWARE	18-8 SS	NONE

MACHINING		SHEET METAL	
X.X	0.0250"	HOLE TO HOLE (SAME SURFACE)	
X.XX	0.0100"	X.X	0.030"
X.XXX	0.0050"	X.XX	0.010"
X.XXXX	0.0005"	X.XXX	0.005"
ANGULAR	0.5°	HOLE TO FOLDED EDGE	
DEBURR ALL		X.X	0.035"
		X.XX	0.025"
		X.XXX	0.015"
		FOLD TO FOLD	
		X.X	0.045"
		X.XX	0.035"
		X.XXX	0.020"
		ANGULAR 1.0°	

APG Vision LLC
4055 Alpha Drive
Allison Park, PA 15101 USA
Phone +1 (412) 487-8211
apgvision.com

apgvision

DESCRIPTION:
35C SEALED 7.5IN BARREL, GLASS VIEWPORT, AIR COOLED, 25mm O.C. ARM & AIR SHIELD FACEPLATE

MATERIAL: **SEE BOM**

FINISH: **SEE BOM**

DRAWN BY: DMM	DATE: 7/22/2022	SCALE: 1:3	SHT-SIZE: B	APPROX. WEIGHT (LBS): 4.0574
CHECKED BY: DMM	DATE: 7/22/2022	PART NUMBER: 35C-MI		REVISION: A

Sheet 1 of 1

1 2 3 4 5 6