

1 2 3 4 5 6

REVISIONS				
ZONE	REV.	DESCRIPTION	DATE	APPROVED
	A	RELEASED FOR PRODUCTION	3/24/2023	DMM

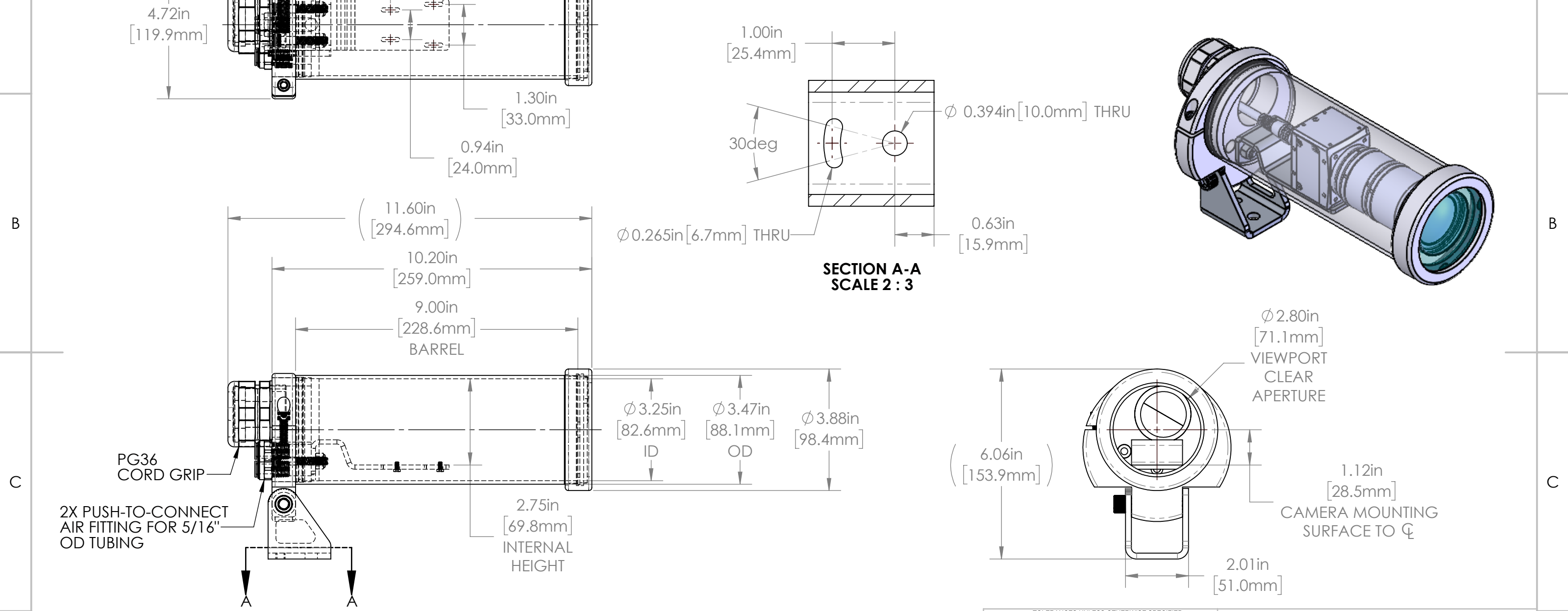

ENVIRONMENT RATING	IP68*	
	(*RATING MAY CHANGE IF INSTALLER MILLS CABLE GLAND OUTSIDE OF TOLERANCE)	
COMPONENT	MATERIAL	FINISH
BODY/BASE/BARREL	6061 ALUMINUM	CLEAR HARDCOAT ANODIZED
PAN & TILT FOOT	304 SS	BURNISHED
VIEWPORT	CLEAR FLOWCOAT ACRYLIC	ABR2
GASKET	VITON	NONE
ARM/ADAPTER	304 SS	NONE
HARDWARE	18-8 SS	NONE

MACHINING		SHEET METAL	
X.X	0.0250"	HOLE TO HOLE (SAME SURFACE)	X.X
X.XX	0.0100"	X.X	0.030"
X.XXX	0.0050"	X.XX	0.010"
X.XXXX	0.0005"	X.XXX	0.005"
ANGULAR	0.5°	HOLE TO FOLDED EDGE	X.X
DEBURR	ALL	X.XX	0.025"
		X.XXX	0.015"
		FOLD TO FOLD	X.X
		X.X	0.045"
		X.XX	0.035"
		X.XXX	0.020"
		ANGULAR	1.0°

APG Vision LLC
4055 Alpha Drive
Allison Park, PA 15101 USA
Phone +1 (412) 487-8211
apgvision.com

apgvision

DESCRIPTION:
35C 9IN BARREL, AIR CURTAIN FACEPLATE, ACRYLIC VIEWPORT, 33mm & 24mm O.C. ARM, FOR KEYENCE CA-HL08MX & CA-LHT25

MATERIAL: SEE BOM

FINISH: SEE BOM

DRAWN BY: GAS	DATE: 3/24/2023	SCALE: 1:3	SHT-SIZE: B	APPROX. WEIGHT (LBS): 4.3543
CHECKED BY: DMM	DATE: 3/24/2023	PART NUMBER: 35C-MQ	REVISION: A	

AS PART OF OUR POLICY OF CONTINUING DEVELOPMENT, APG VISION LLC RESERVES THE RIGHT TO ALTER SPECIFICATIONS WITHOUT PRIOR NOTICE.

Sheet 1 of 1

1 2 3 4 5 6