

1 2 3 4 5 6

A A

B B

C C

D D

REVISIONS				
ZONE	REV.	DESCRIPTION	DATE	APPROVED
	A	RELEASED FOR PRODUCTION	10/22/2021	DMM

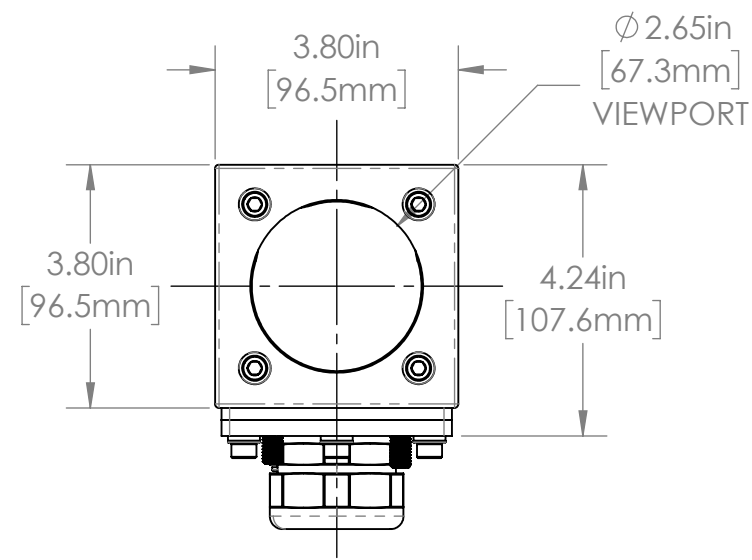
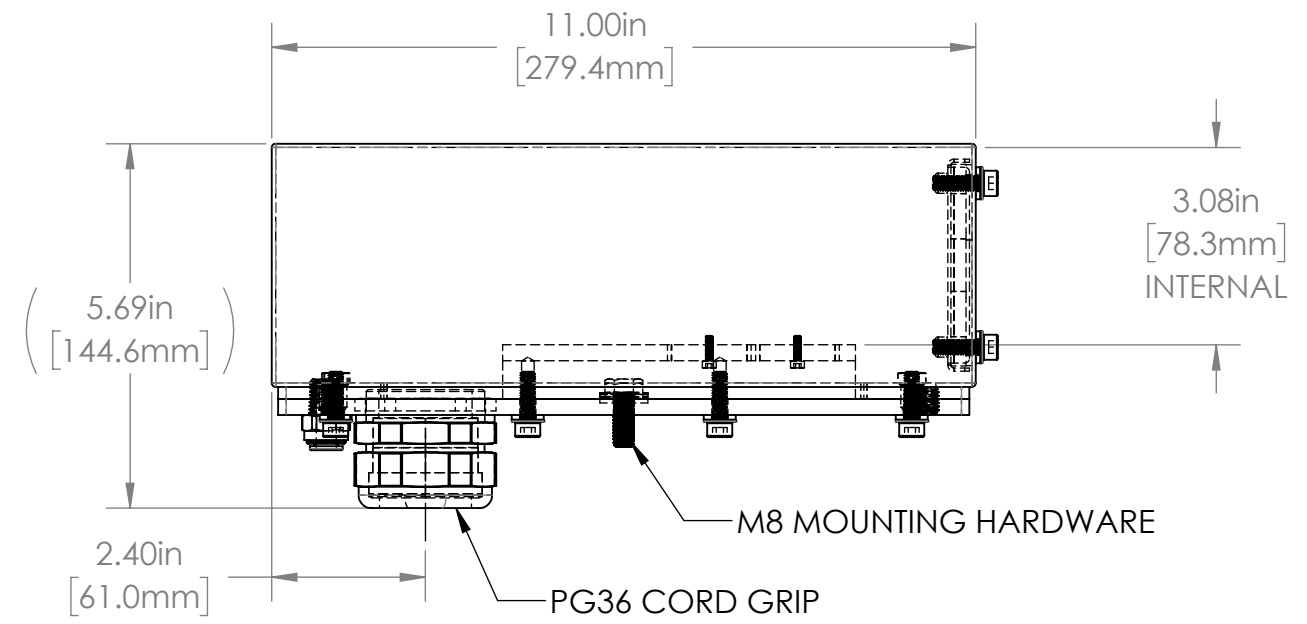
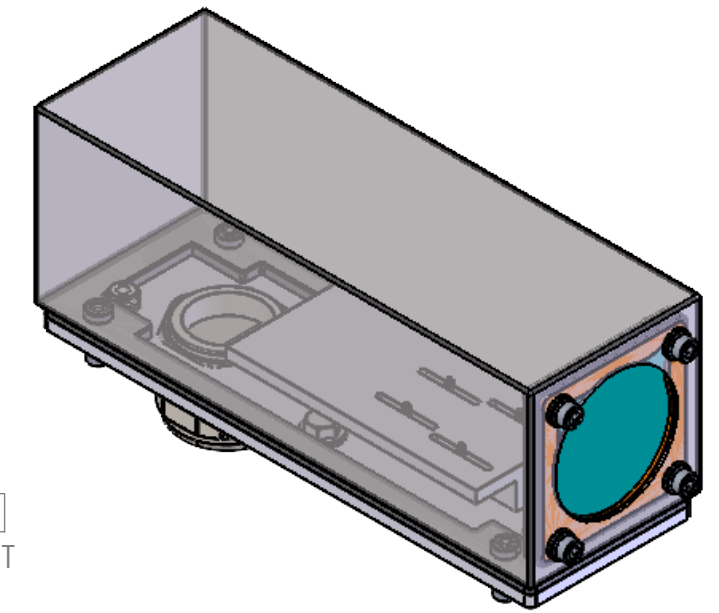
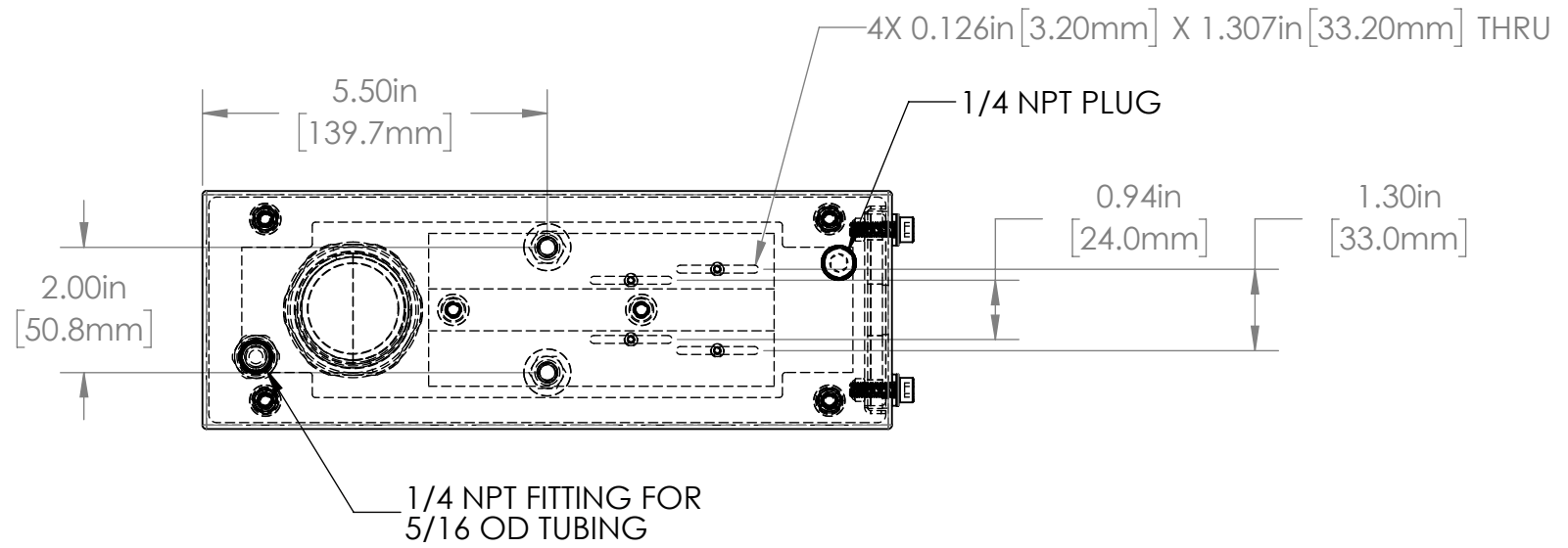

38D SERIES PROPERTIES TABLE

ENVIRONMENT RATING	IP52*	
	(*RATING MAY CHANGE IF INSTALLER MILLS CABLE GLAND OUTSIDE OF TOLERANCE)	
COMPONENT	MATERIAL	FINISH
BODY	304 SS	BURNISHED
BASE	6061 ALUMINUM	CLEAR HARDCOAT ANODIZED
VIEWPORT	CLEAR FLOWCOAT ACRYLIC	ABR2
GASKET	EPDM FOAM / 40D SILICONE	NONE
ARM	6061 ALUMINUM	CLEAR HARDCOAT ANODIZED
HARDWARE	316 SS - EXTERNAL, 18-8 SS - INTERNAL	NONE

TOLERANCES UNLESS OTHERWISE SPECIFIED

MACHINING	SHEET METAL
X.X 0.0250"	HOLE TO HOLE (SAME SURFACE) X.X 0.030"
X.XX 0.0100"	X.XX 0.010"
X.XXX 0.0050"	X.XXX 0.005"
X.XXXX 0.0005"	X.XXX 0.015"
ANGULAR 0.5°	HOLE TO FOLDED EDGE X.X 0.035"
DEBURR ALL	X.XX 0.025"
	X.XXX 0.015"
	FOLD TO FOLD X.X 0.045"
	X.XX 0.035"
	X.XXX 0.020"
	ANGULAR 1.0°

THIS PRINT IS THE PROPERTY OF APG VISION LLC. THE INFORMATION CONTAINED HEREIN IS CONFIDENTIAL. IT IS NOT TRANSFERABLE. IT IS FURNISHED WITH THE CLEAR UNDERSTANDING THAT IT IS NOT TO BE TRACED, REPRODUCED OR USED IN ANY PROCESS OF MANUFACTURING WITHOUT WRITTEN PERMISSION FROM THE OWNER AND IS RETURNABLE UPON DEMAND. ANY INFRINGEMENT UPON THE PATENT RIGHTS SHOWN HEREIN, WHETHER IN PART OR WHOLE, WILL BE PROSECUTED.

AS PART OF OUR POLICY OF CONTINUING DEVELOPMENT, APG VISION LLC RESERVES THE RIGHT TO ALTER SPECIFICATIONS WITHOUT PRIOR NOTICE.

APG Vision LLC
4055 Alpha Drive
Allison Park, PA 15101 USA
Phone +1 (412) 487-8211
apgvision.com

apgvision

DESCRIPTION:
**38D 11IN ACFP ENCLOSURE
SLOTTED ARM 33mm & 24mm O.C.**

MATERIAL: SEE BOM

FINISH: SEE BOM

DRAWN BY: DMM	DATE: 10/22/2021	SCALE: 1:3	SHT-SIZE: B	APPROX. WEIGHT (LBS): 4.9493
CHECKED BY: DMM	DATE: 10/22/2021	PART NUMBER: 38D-DS		REVISION: A

Sheet 1 of 1

1 2 3 4 5 6