

1 2 3 4 5 6

A A

B B

C C

D D

REVISIONS				
ZONE	REV.	DESCRIPTION	DATE	APPROVED
	A	RELEASED FOR PRODUCTION	11/2/2021	DMM

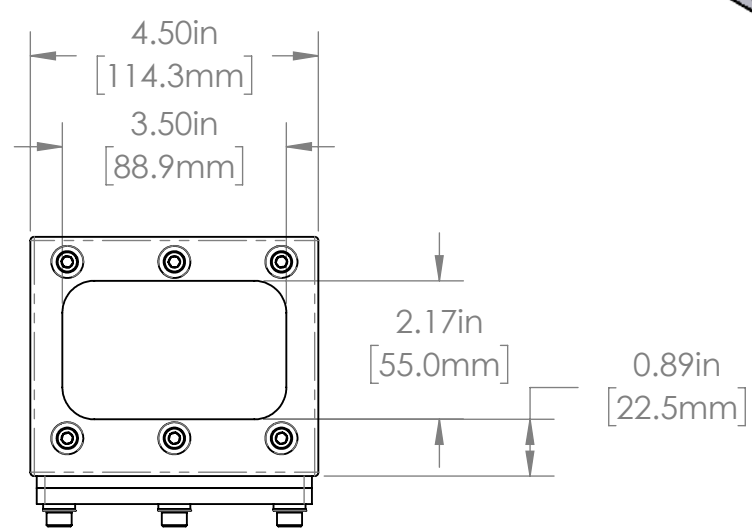
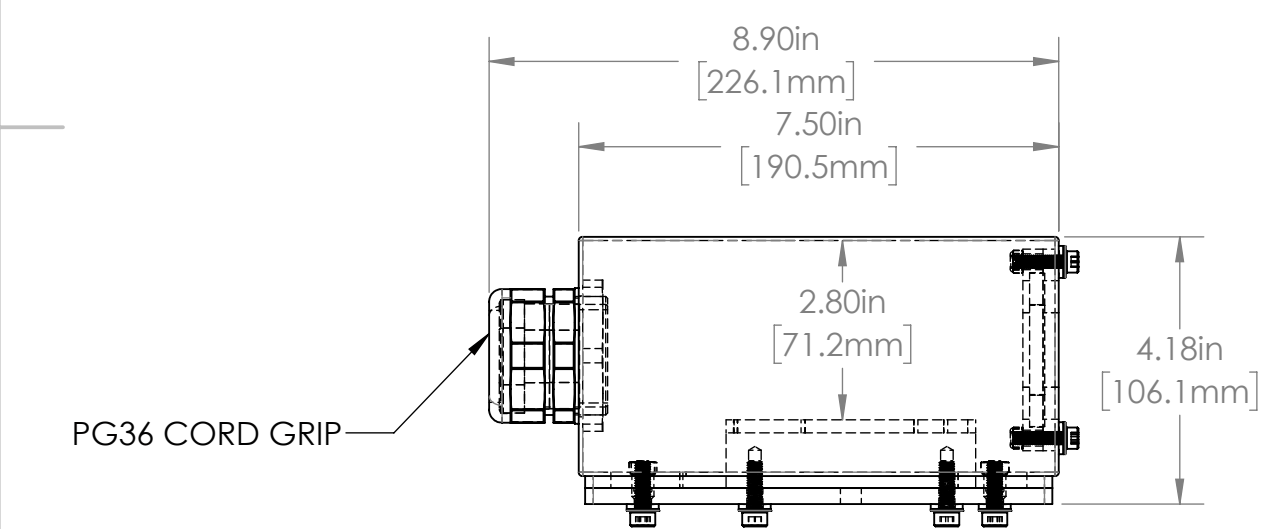
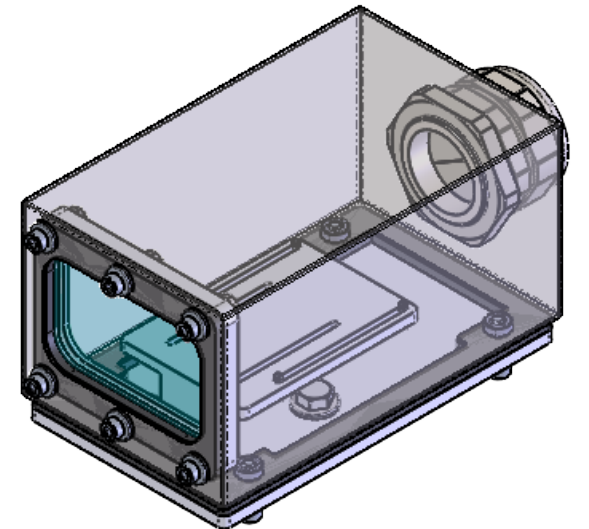
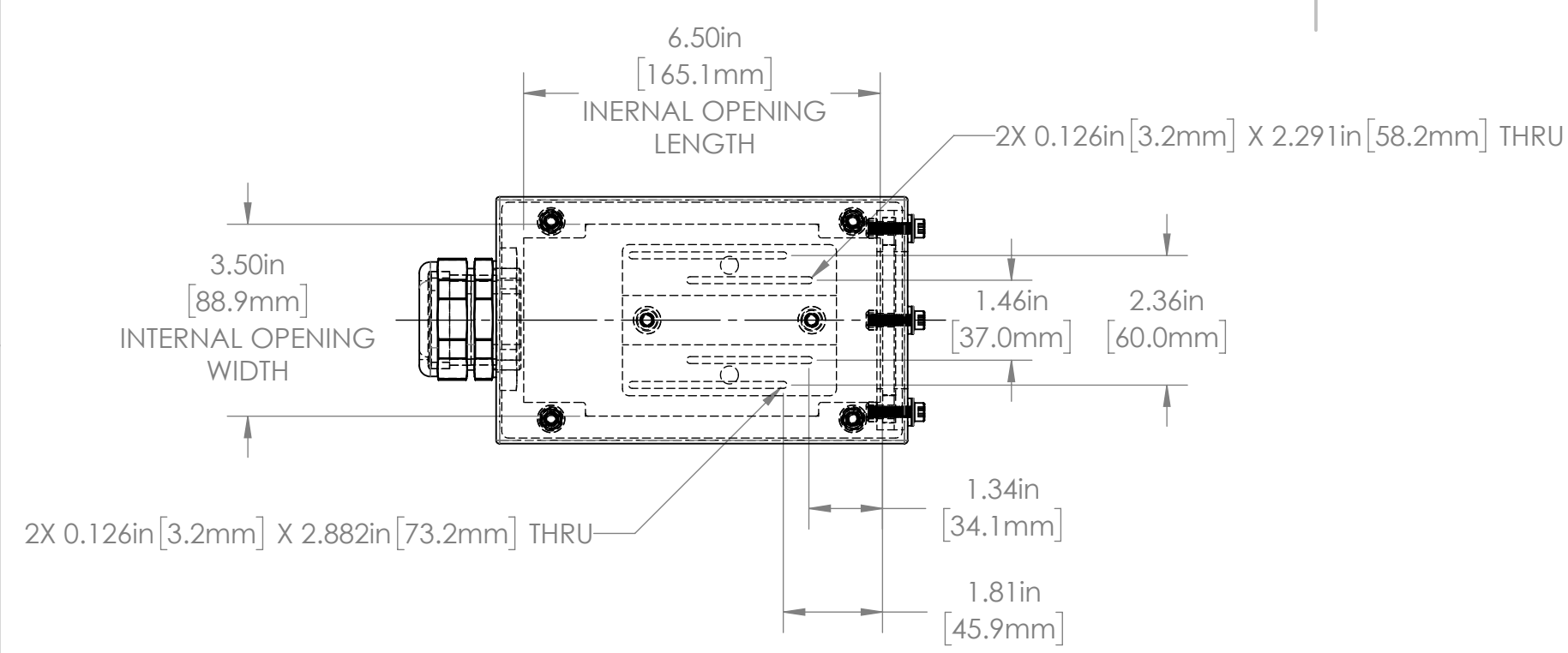

42D SERIES PROPERTIES TABLE

ENVIRONMENT RATING	IP64*	
	(*RATING MAY CHANGE IF INSTALLER MILLS CABLE GLAND OUTSIDE OF TOLERANCE)	
COMPONENT	MATERIAL	FINISH
BODY	304 SS	BURNISHED
BASE	6061 ALUMINUM	CLEAR HARDCOAT ANODIZED
VIEWPORT	CLEAR FLOW COAT ACRYLIC	ABR2
GASKET	EPDM FOAM	NONE
ARM/ADAPTOR	6061 ALUMINUM	NONE
HARDWARE	18-8 SS	NONE

TOLERANCES UNLESS OTHERWISE SPECIFIED

MACHINING		SHEET METAL	
X.X	0.0250"	HOLE TO HOLE (SAME SURFACE)	
X.XX	0.0100"	X.X	0.030"
X.XXX	0.0050"	X.XX	0.010"
X.XXXX	0.0005"	X.XXX	0.005"
ANGULAR	0.5°	HOLE TO FOLDED EDGE	
DEBURR ALL		X.X	0.035"
		X.XX	0.025"
		X.XXX	0.015"
		FOLD TO FOLD	
		X.X	0.045"
		X.XX	0.035"
		X.XXX	0.020"
		ANGULAR 1.0°	

THIS PRINT IS THE PROPERTY OF APG VISION LLC. THE INFORMATION CONTAINED HEREIN IS CONFIDENTIAL. IT IS NOT TRANSFERABLE. IT IS FURNISHED WITH THE CLEAR UNDERSTANDING THAT IT IS NOT TO BE TRACED, REPRODUCED OR USED IN ANY PROCESS OF MANUFACTURING WITHOUT WRITTEN PERMISSION FROM THE OWNER AND IS RETURNABLE UPON DEMAND. ANY INFRINGEMENT UPON THE PATENT RIGHTS SHOWN HEREIN, WHETHER IN PART OR WHOLE, WILL BE PROSECUTED.

AS PART OF OUR POLICY OF CONTINUING DEVELOPMENT, APG VISION LLC RESERVES THE RIGHT TO ALTER SPECIFICATIONS WITHOUT PRIOR NOTICE.

APG Vision LLC
4055 Alpha Drive
Allison Park, PA 15101 USA
Phone +1 (412) 487-8211
apgvision.com

apgvision

DESCRIPTION:
**42D 7.5IN SEALED ENCLOSURE
ACRYLIC VIEWPORT 37mm & 60mm O.C.**

MATERIAL: SEE PROPERTIES TABLE

FINISH: SEE PROPERTIES TABLE

DRAWN BY:	DATE:	SCALE:	SHT-SIZE:	APPROX. WEIGHT (LBS)
TWD	11/1/2021	1:3	B	3.9887
CHECKED BY:	DATE:	PART NUMBER:	REVISION	
DMM	11/2/2021	42D-AA	A	

Sheet1 of 2

1 2 3 4 5 6

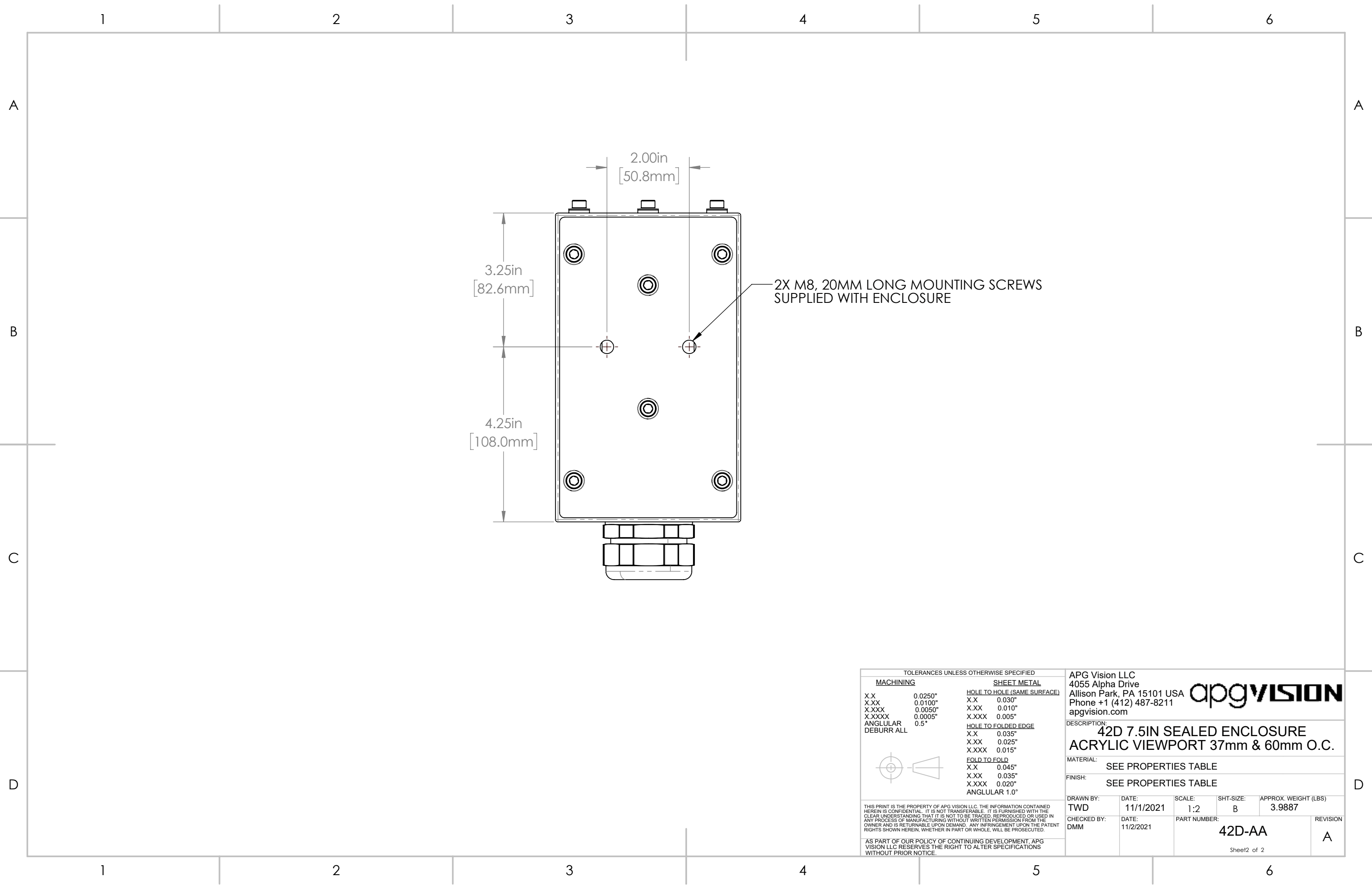

2X M8, 20MM LONG MOUNTING SCREWS
SUPPLIED WITH ENCLOSURE

TOLERANCES UNLESS OTHERWISE SPECIFIED

MACHINING		SHEET METAL	
X.X	0.0250"	<u>HOLE TO HOLE (SAME SURFACE)</u>	
X.XX	0.0100"	X.X	0.030"
X.XXX	0.0050"	X.XX	0.010"
X.XXXX	0.0005"	X.XXX	0.005"
ANGULAR	0.5°	<u>HOLE TO FOLDED EDGE</u>	
DEBURR ALL		X.X	0.035"
		X.XX	0.025"
		X.XXX	0.015"
		<u>FOLD TO FOLD</u>	
		X.X	0.045"
		X.XX	0.035"
		X.XXX	0.020"
		ANGULAR 1.0°	

THIS PRINT IS THE PROPERTY OF APG VISION LLC. THE INFORMATION CONTAINED HEREIN IS CONFIDENTIAL. IT IS NOT TRANSFERABLE. IT IS FURNISHED WITH THE CLEAR UNDERSTANDING THAT IT IS NOT TO BE TRACED, REPRODUCED OR USED IN ANY PROCESS OF MANUFACTURING WITHOUT WRITTEN PERMISSION FROM THE OWNER AND IS RETURNABLE UPON DEMAND. ANY INFRINGEMENT UPON THE PATENT RIGHTS SHOWN HEREIN, WHETHER IN PART OR WHOLE, WILL BE PROSECUTED.

AS PART OF OUR POLICY OF CONTINUING DEVELOPMENT, APG VISION LLC RESERVES THE RIGHT TO ALTER SPECIFICATIONS WITHOUT PRIOR NOTICE.

APG Vision LLC
4055 Alpha Drive
Allison Park, PA 15101 USA
Phone +1 (412) 487-8211
apgvision.com

apgvision

DESCRIPTION:
**42D 7.5IN SEALED ENCLOSURE
ACRYLIC VIEWPORT 37mm & 60mm O.C.**

MATERIAL: SEE PROPERTIES TABLE

FINISH: SEE PROPERTIES TABLE

DRAWN BY: TWD	DATE: 11/1/2021	SCALE: 1:2	SHT-SIZE: B	APPROX. WEIGHT (LBS): 3.9887
CHECKED BY: DMM	DATE: 11/2/2021	PART NUMBER: 42D-AA		REVISION: A

Sheet2 of 2