

1 2 3 4 5 6

REVISIONS				
ZONE	REV.	DESCRIPTION	DATE	APPROVED
	A	RELEASED FOR PRODUCTION	6/8/2022	DMM

A

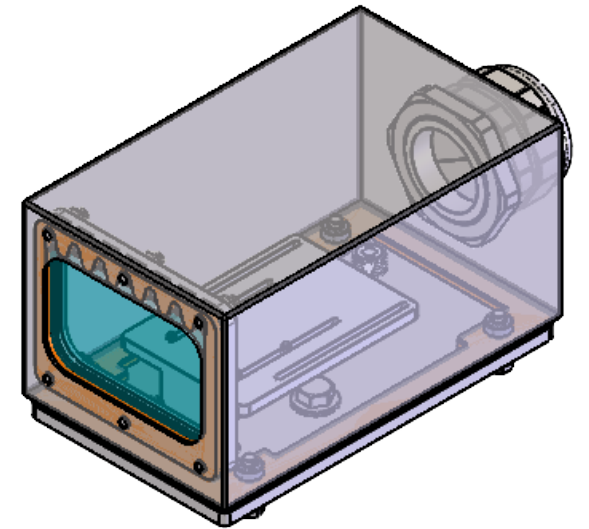
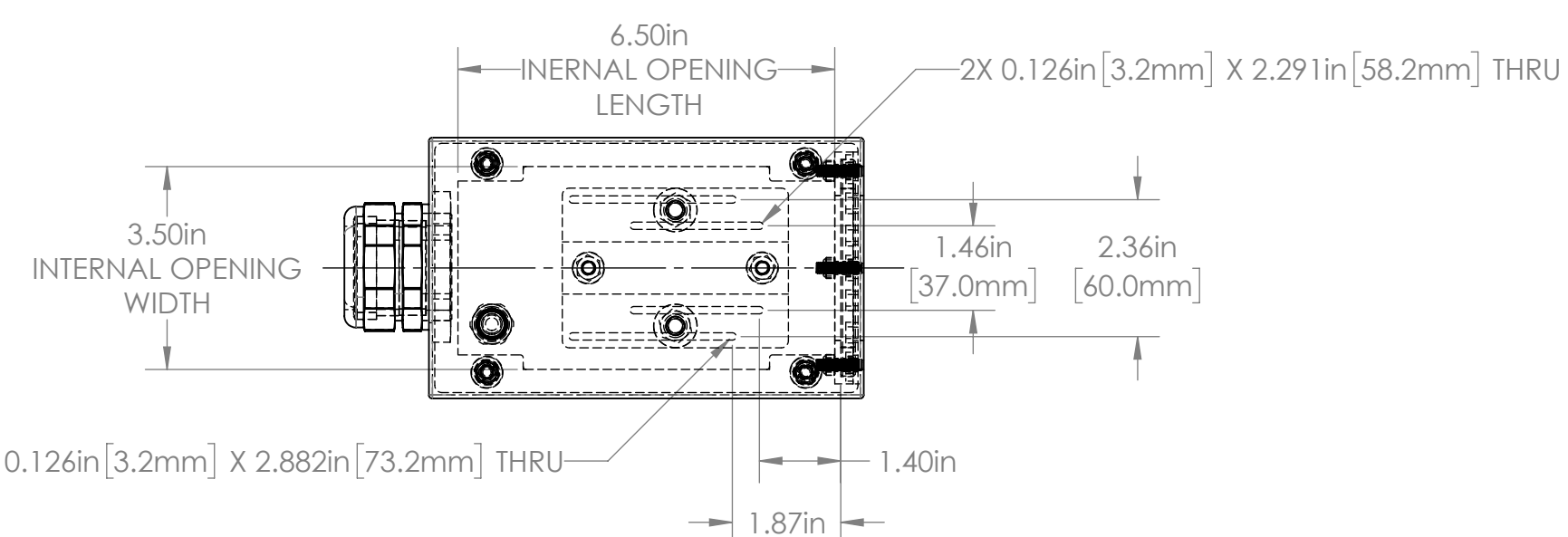

B

B

C

C

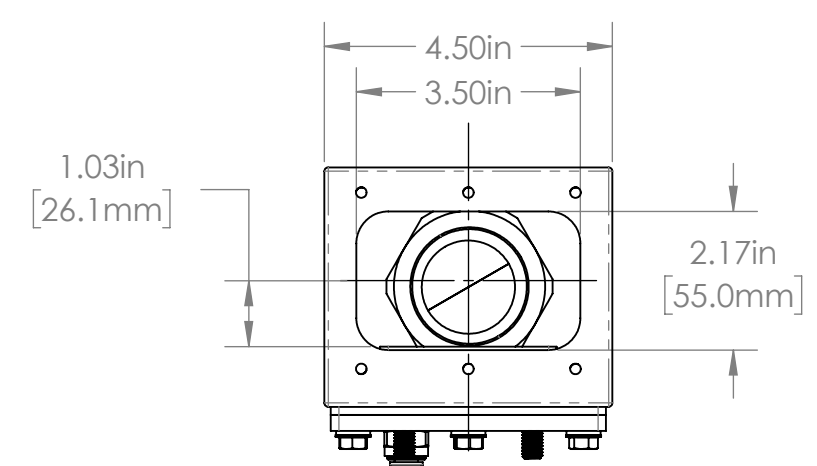
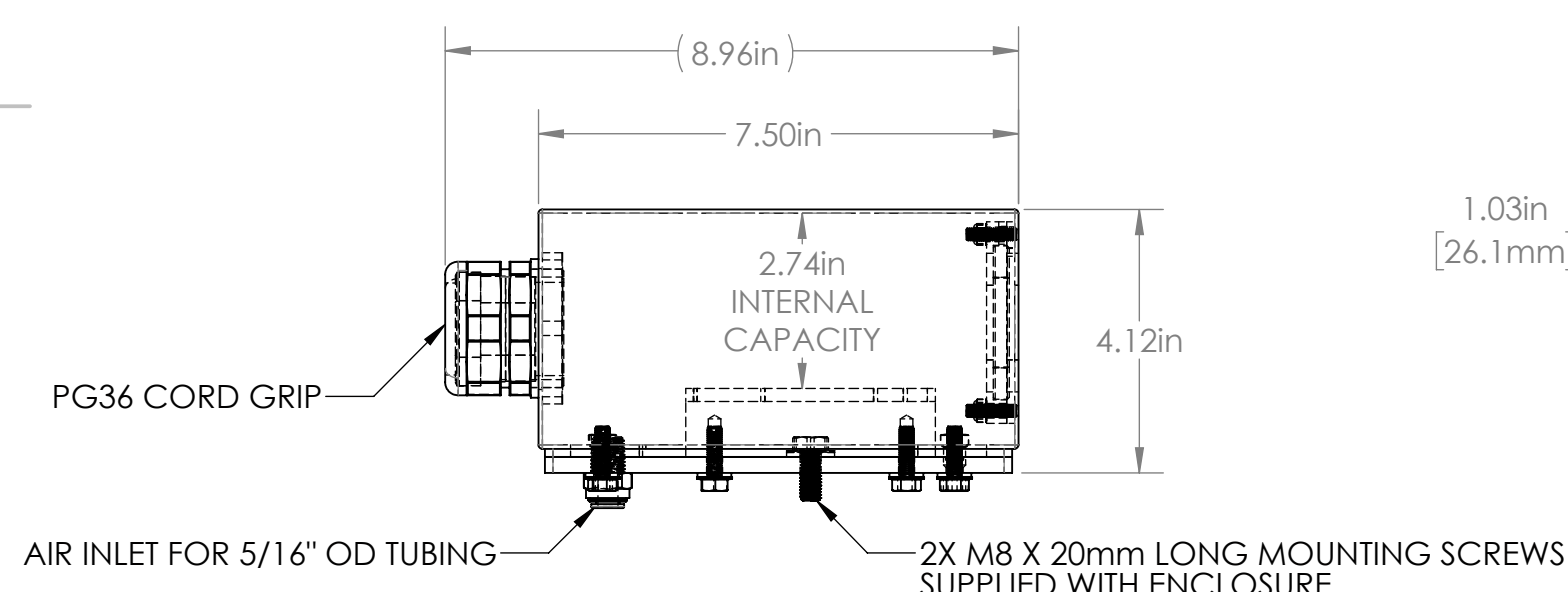

42S SERIES PROPERTIES TABLE

ENVIRONMENT RATING	IP52*	
	(*RATING MAY CHANGE IF INSTALLER MILLS CABLE GLAND OUTSIDE OF TOLERANCE)	
COMPONENT	MATERIAL	FINISH
BODY/BASE	316 SS	BURNISHED
VIEWPORT	CLEAR FLOW COAT ACRYLIC	ABR2
GASKET	SILICONE	NONE
ARM/ADAPTOR	6061 ALUM	NONE
HARDWARE	316 SS - EXTERNAL, 18-8 SS - INTERNAL	AS SUPPLIED

TOLERANCES UNLESS OTHERWISE SPECIFIED

MACHINING	SHEET METAL
X.X 0.0250"	HOLE TO HOLE (SAME SURFACE) X.X 0.030"
X.XX 0.0100"	X.XX 0.010"
X.XXX 0.0050"	X.XXX 0.005"
X.XXXX 0.0005"	X.XXX 0.015"
ANGULAR 0.5°	HOLE TO FOLDED EDGE X.X 0.035"
DEBURR ALL	X.XX 0.025"
	X.XXX 0.015"
	FOLD TO FOLD X.X 0.045"
	X.XX 0.035"
	X.XXX 0.020"
	ANGULAR 1.0°

THIS PRINT IS THE PROPERTY OF APG VISION LLC. THE INFORMATION CONTAINED HEREIN IS CONFIDENTIAL. IT IS NOT TRANSFERABLE. IT IS FURNISHED WITH THE CLEAR UNDERSTANDING THAT IT IS NOT TO BE TRACED, REPRODUCED OR USED IN ANY PROCESS OF MANUFACTURING WITHOUT WRITTEN PERMISSION FROM THE OWNER AND IS RETURNABLE UPON DEMAND. ANY INFRINGEMENT UPON THE PATENT RIGHTS SHOWN HEREIN, WHETHER IN PART OR WHOLE, WILL BE PROSECUTED.

AS PART OF OUR POLICY OF CONTINUING DEVELOPMENT, APG VISION LLC RESERVES THE RIGHT TO ALTER SPECIFICATIONS WITHOUT PRIOR NOTICE.

APG Vision LLC
4055 Alpha Drive
Allison Park, PA 15101 USA
Phone +1 (412) 487-8211
apgvision.com

apgvision

DESCRIPTION:
42S, 7.5IN ENCLOSURE, PG36, ACFP, 37mm & 60mm O.C. ARM

MATERIAL:
SEE PROPERTIES TABLE

FINISH:
SEE PROPERTIES TABLE

DRAWN BY: TWD	DATE: 6/8/2022	SCALE: 1:3	SHT-SIZE: B	APPROX. WEIGHT (LBS) 5.7405
CHECKED BY: DMM	DATE: 6/8/2022	PART NUMBER: 42S-AF	REVISION: A	

Sheet1 of 1

1 2 3 4 5 6

D

D