

6 5 4 3 2 1

D

C

B

A

D

C

B

A

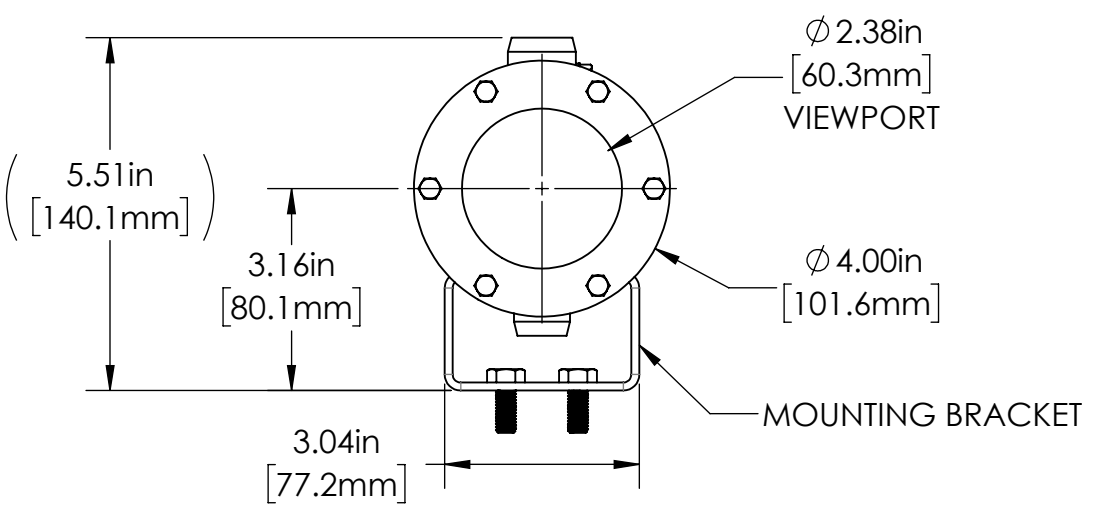
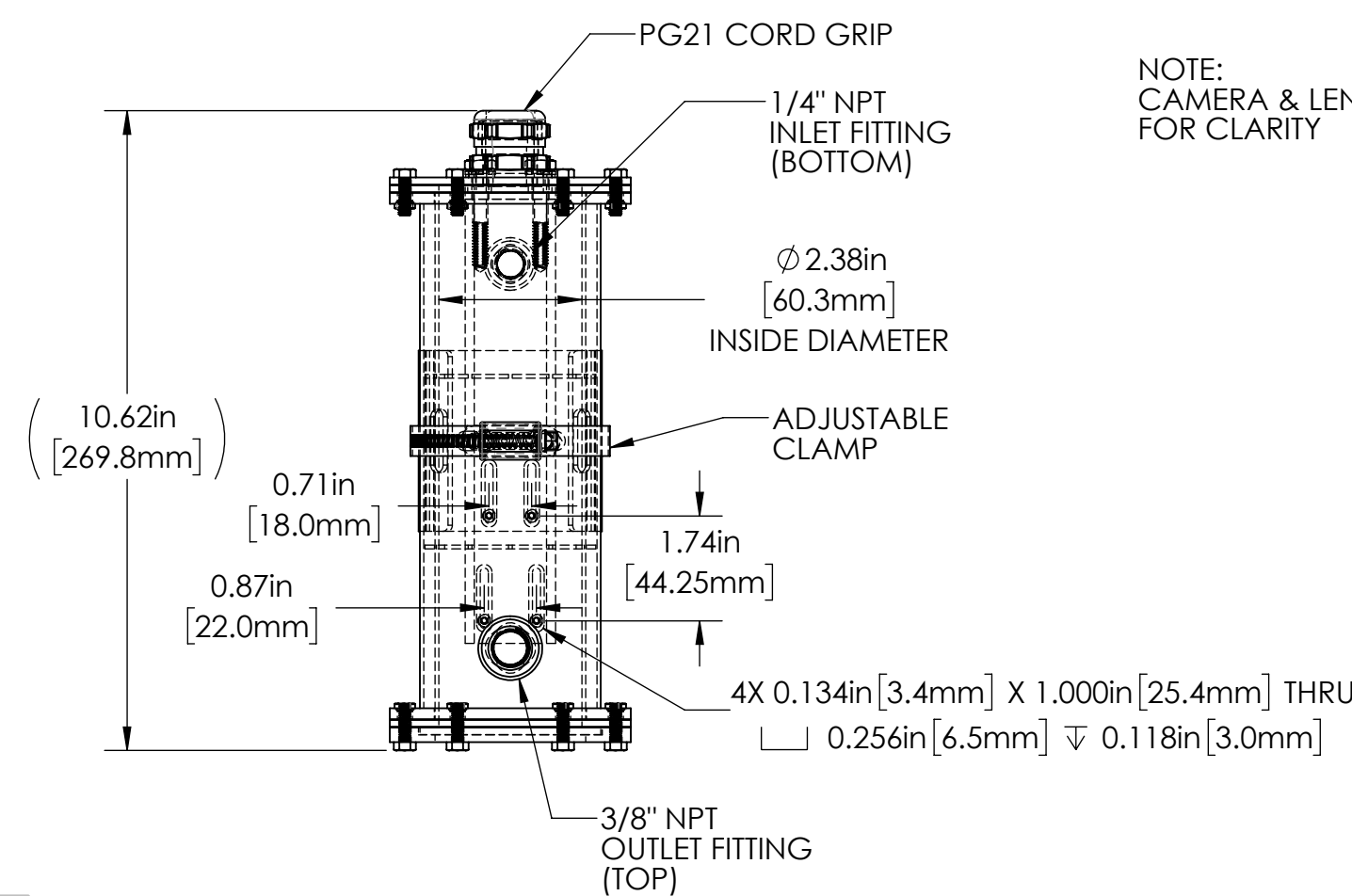

NOTE:  
CAMERA & LENS HIDDEN  
FOR CLARITY

REVISIONS				
ZONE	REV.	DESCRIPTION	DATE	APPROVED
	A	RELEASED FOR CUSTOMER APPROVAL	2/9/2022	DMM

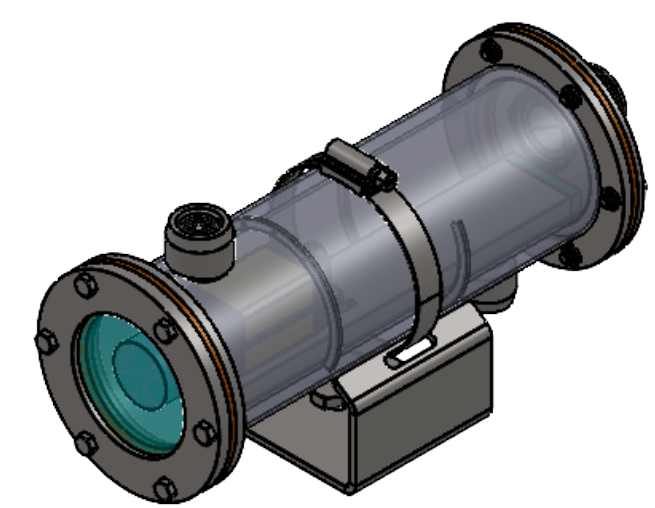
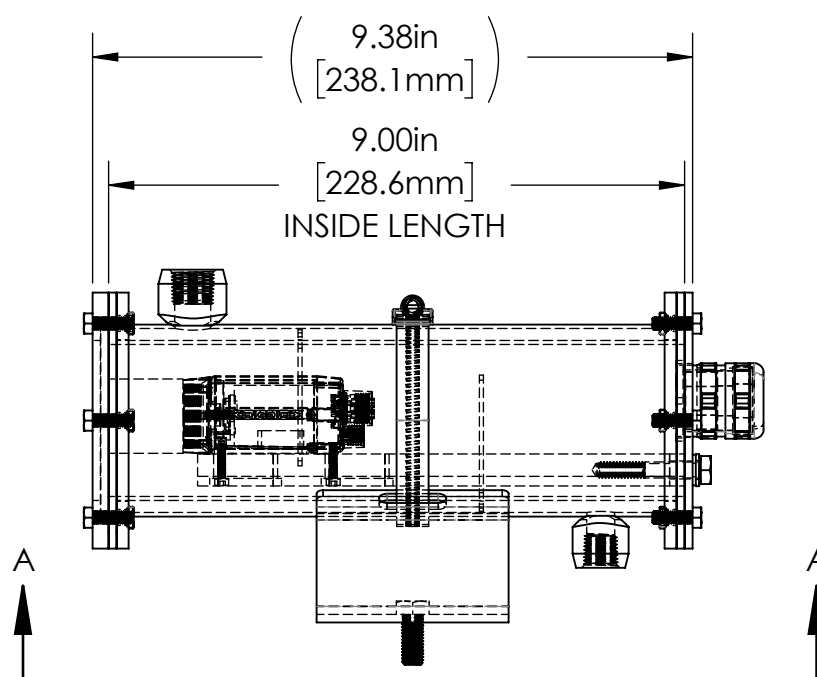
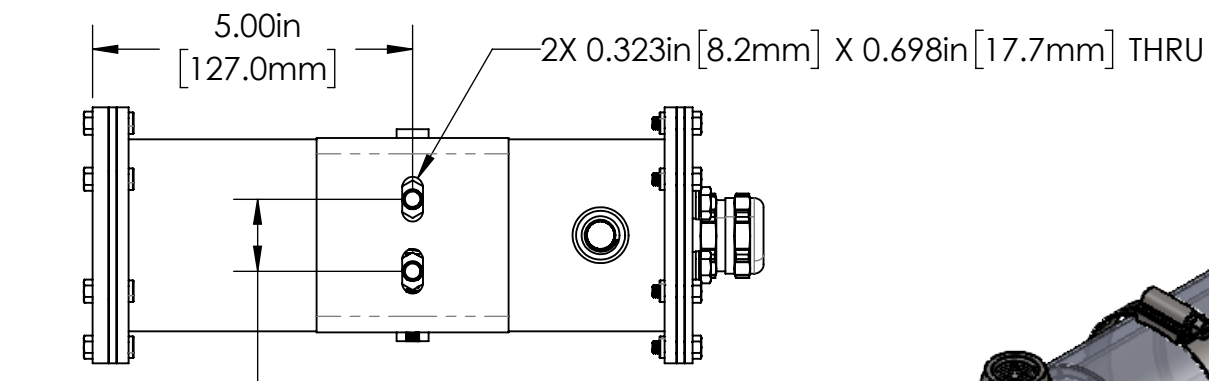

**CC SERIES PROPERTIES TABLE**

<b>ENVIRONMENT RATING</b>	IP68*	
	(*RATING MAY CHANGE IF INSTALLER MILLS CABLE GLAND OUTSIDE OF TOLERANCE)	
<b>COMPONENT</b>	<b>MATERIAL</b>	<b>FINISH</b>
BODY	316 SS	BURNISHED
VIEWPORT	BOROSILICATE GLASS	NONE
GASKET	40D SILICONE	NONE
ARM/ADAPTER	6061 ALUMINUM/304 SS	NONE
HARDWARE	316 SS - EXTERNAL, 18-8 SS - INTERNAL	NONE

TOLERANCES UNLESS OTHERWISE SPECIFIED

MACHINING	SHEET METAL
X.X 0.0250"	HOLE TO HOLE (SAME SURFACE) X.X 0.030"
X.XX 0.0100"	X.XX 0.010"
X.XXX 0.0050"	X.XXX 0.005"
X.XXXX 0.0005"	X.XXX 0.015"
ANGULAR 0.5°	HOLE TO FOLDED EDGE X.X 0.035"
DEBURR ALL	X.XX 0.025"
	X.XXX 0.015"
	FOLD TO FOLD X.X 0.045"
	X.XX 0.035"
	X.XXX 0.020"
	ANGULAR 1.0°

THIS PRINT IS THE PROPERTY OF APG VISION LLC. THE INFORMATION CONTAINED HEREIN IS CONFIDENTIAL. IT IS NOT TRANSFERABLE. IT IS FURNISHED WITH THE CLEAR UNDERSTANDING THAT IT IS NOT TO BE TRACED, REPRODUCED OR USED IN ANY PROCESS OF MANUFACTURING WITHOUT WRITTEN PERMISSION FROM THE OWNER AND IS RETURNABLE UPON DEMAND. ANY INFRINGEMENT UPON THE PATENT RIGHTS SHOWN HEREIN, WHETHER IN PART OR WHOLE, WILL BE PROSECUTED.

AS PART OF OUR POLICY OF CONTINUING DEVELOPMENT, APG VISION LLC RESERVES THE RIGHT TO ALTER SPECIFICATIONS WITHOUT PRIOR NOTICE.

APG Vision LLC  
4055 Alpha Drive  
Allison Park, PA 15101 USA  
Phone +1 (412) 487-8211  
apgvision.com

**apgvision**

DESCRIPTION:  
LIQUID COOLED ENCLOSURE FOR COGNEX  
IN-SIGHT 8200 WITH FUJINON HF50HA-1S

MATERIAL: SEE PROPERTIES TABLE

FINISH: SEE PROPERTIES TABLE

DRAWN BY: GAS	DATE: 2/9/2022	SCALE: 1:3	SHT-SIZE: B	APPROX. WEIGHT (LBS): 6.50
CHECKED BY: DMM	DATE: 2/9/2022	PART NUMBER: CC-BP	REVISION: A	

Sheet 1 of 1

6 5 4 3 2 1