

NOTE: OPTIONAL HEATER COMPONENTS NOT SHOWN

REVISIONS				
ZONE	REV.	DESCRIPTION	DATE	APPROVED
	A	RELEASED FOR PRODUCTION	12/7/2021	DMM

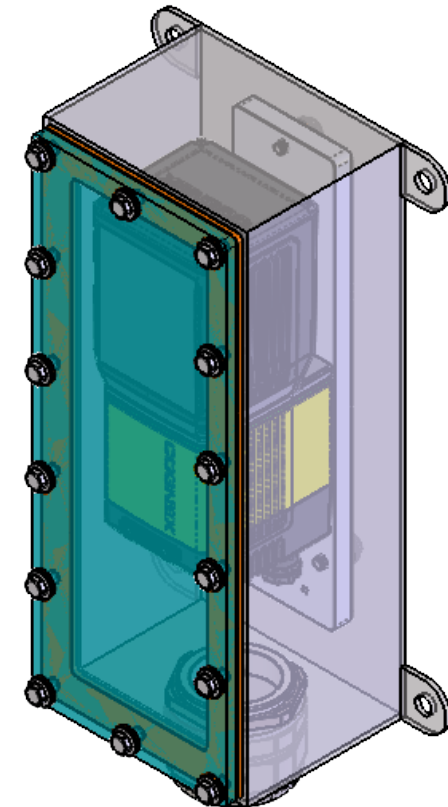
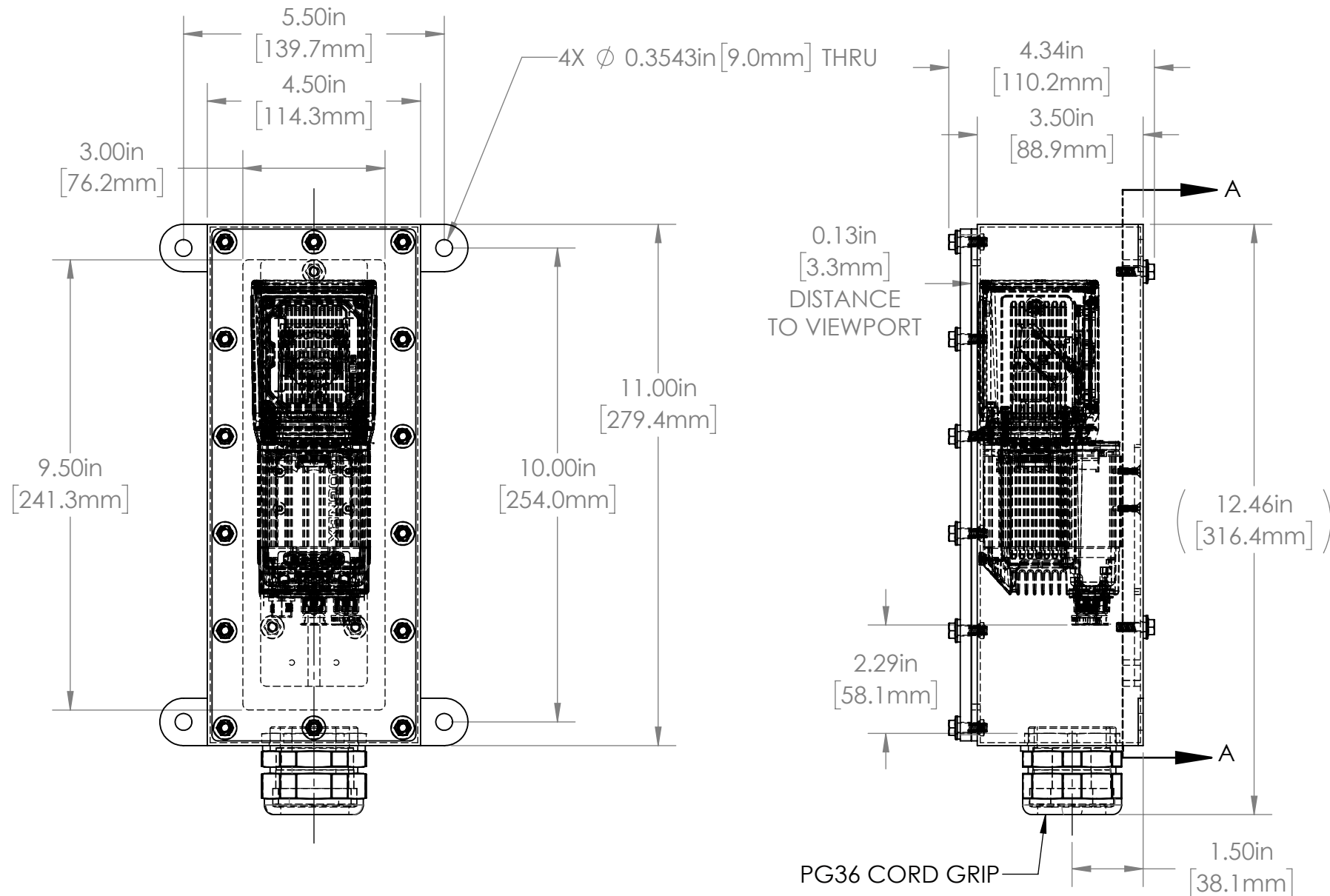

**LD SERIES PROPERTIES TABLE**

<b>ENVIRONMENT RATING</b>	IP69K*	
	(*RATING MAY CHANGE IF INSTALLER MILLS CABLE GLAND OUTSIDE OF TOLERANCE)	
<b>COMPONENT</b>	<b>MATERIAL</b>	<b>FINISH</b>
BODY	316 SS	BURNISHED
VIEWPORT	CLEAR FLOW COAT ACRYLIC	ABR2
GASKET	40D SILICONE	NONE
ARM/ADAPTOR	6061 ALUMINUM	NONE
HARDWARE	316 SS - EXTERNAL, 18-8 SS - INTERNAL	NONE

TOLERANCES UNLESS OTHERWISE SPECIFIED

MACHINING		SHEET METAL	
X.X	0.0250"	HOLE TO HOLE (SAME SURFACE)	
X.XX	0.0100"	X.X	0.030"
X.XXX	0.0050"	X.XX	0.010"
X.XXXX	0.0005"	X.XXX	0.005"
ANGULAR	0.5°	X.XXX	0.015"
DEBURR ALL		HOLE TO FOLDED EDGE	
		X.X	0.035"
		X.XX	0.025"
		X.XXX	0.015"
		FOLD TO FOLD	
		X.X	0.045"
		X.XX	0.035"
		X.XXX	0.020"
		ANGULAR 1.0°	

THIS PRINT IS THE PROPERTY OF APG VISION LLC. THE INFORMATION CONTAINED HEREIN IS CONFIDENTIAL. IT IS NOT TRANSFERABLE. IT IS FURNISHED WITH THE CLEAR UNDERSTANDING THAT IT IS NOT TO BE TRACED, REPRODUCED OR USED IN ANY PROCESS OF MANUFACTURING WITHOUT WRITTEN PERMISSION FROM THE OWNER AND IS RETURNABLE UPON DEMAND. ANY INFRINGEMENT UPON THE PATENT RIGHTS SHOWN HEREIN, WHETHER IN PART OR WHOLE, WILL BE PROSECUTED.

AS PART OF OUR POLICY OF CONTINUING DEVELOPMENT, APG VISION LLC RESERVES THE RIGHT TO ALTER SPECIFICATIONS WITHOUT PRIOR NOTICE.

APG Vision LLC  
4055 Alpha Drive  
Allison Park, PA 15101 USA  
Phone +1 (412) 487-8211  
apgvision.com

**apgvision**

DESCRIPTION:  
LD IP69K ENCLOSURE FOR COGNEX DM470 HSSM MIRROR WITH PROVISIONS FOR HEATER & THERMOSTAT

MATERIAL: SEE BOM

FINISH: SEE BOM

DRAWN BY: DMM	DATE: 12/7/2021	SCALE: 1:3	SHT-SIZE: B	APPROX. WEIGHT (LBS): 5.2745
CHECKED BY: DMM	DATE: 12/7/2021	PART NUMBER: LD-FP		REVISION: A

Sheet 1 of 2

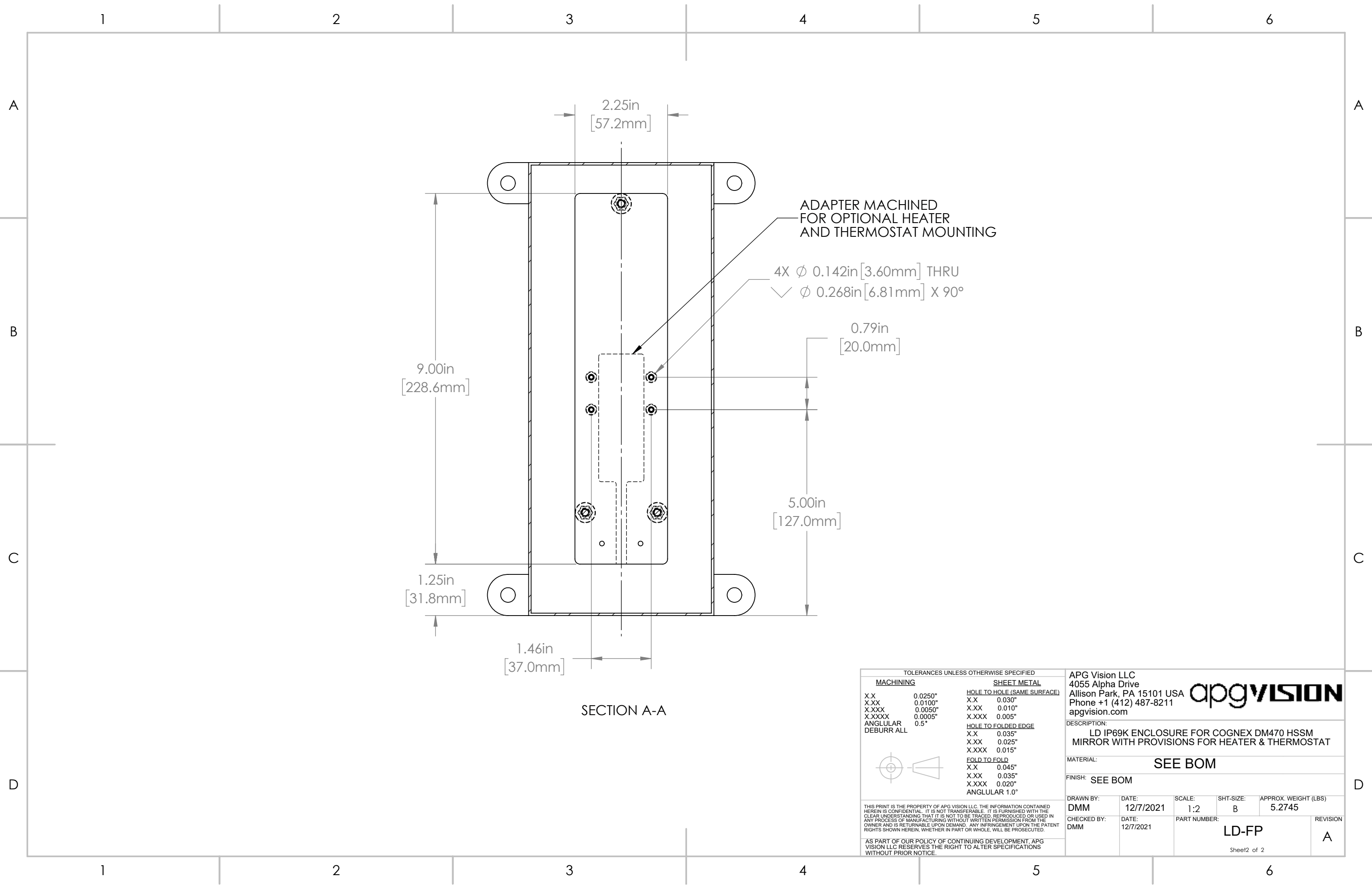

TOLERANCES UNLESS OTHERWISE SPECIFIED

MACHINING		SHEET METAL	
X.X	0.0250"	HOLE TO HOLE (SAME SURFACE)	
X.XX	0.0100"	X.X	0.030"
X.XXX	0.0050"	X.XX	0.010"
X.XXXX	0.0005"	X.XXX	0.005"
ANGULAR	0.5°	HOLE TO FOLDED EDGE	
DEBURR ALL		X.X	0.035"
		X.XX	0.025"
		X.XXX	0.015"
		FOLD TO FOLD	
		X.X	0.045"
		X.XX	0.035"
		X.XXX	0.020"
		ANGULAR 1.0°	

THIS PRINT IS THE PROPERTY OF APG VISION LLC. THE INFORMATION CONTAINED HEREIN IS CONFIDENTIAL. IT IS NOT TRANSFERABLE. IT IS FURNISHED WITH THE CLEAR UNDERSTANDING THAT IT IS NOT TO BE TRACED, REPRODUCED OR USED IN ANY PROCESS OF MANUFACTURING WITHOUT WRITTEN PERMISSION FROM THE OWNER AND IS RETURNABLE UPON DEMAND. ANY INFRINGEMENT UPON THE PATENT RIGHTS SHOWN HEREIN, WHETHER IN PART OR WHOLE, WILL BE PROSECUTED.

AS PART OF OUR POLICY OF CONTINUING DEVELOPMENT, APG VISION LLC RESERVES THE RIGHT TO ALTER SPECIFICATIONS WITHOUT PRIOR NOTICE.

APG Vision LLC  
 4055 Alpha Drive  
 Allison Park, PA 15101 USA  
 Phone +1 (412) 487-8211  
 apgvision.com

**apgvision**

DESCRIPTION:  
 LD IP69K ENCLOSURE FOR COGNEX DM470 HSSM MIRROR WITH PROVISIONS FOR HEATER & THERMOSTAT

MATERIAL: SEE BOM

FINISH: SEE BOM

DRAWN BY: DMM	DATE: 12/7/2021	SCALE: 1:2	SHT-SIZE: B	APPROX. WEIGHT (LBS) 5.2745
CHECKED BY: DMM	DATE: 12/7/2021	PART NUMBER: LD-FP		REVISION A

Sheet2 of 2