

1 2 3 4 5 6

A

B

C

D

A

B

C

D

REVISIONS				
ZONE	REV.	DESCRIPTION	DATE	APPROVED
	A	RELEASED FOR PRODUCTION	3/1/2023	DMM

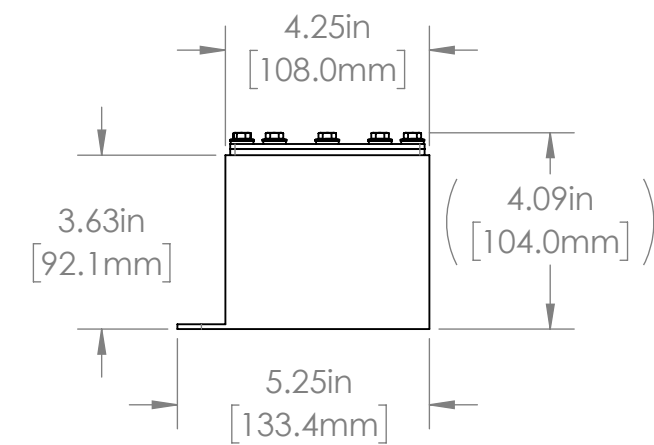
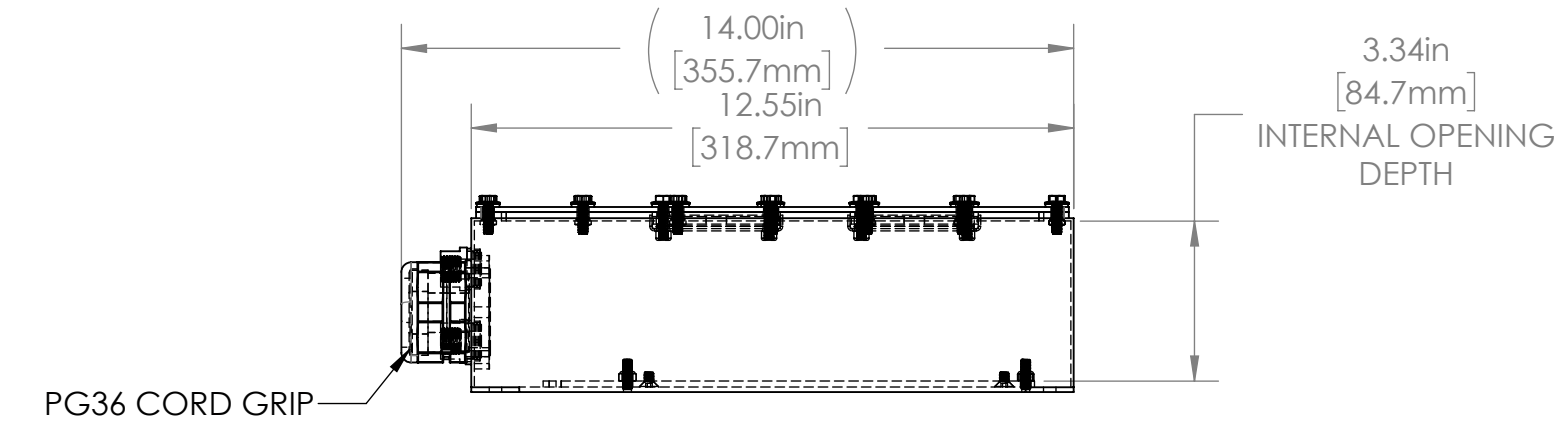
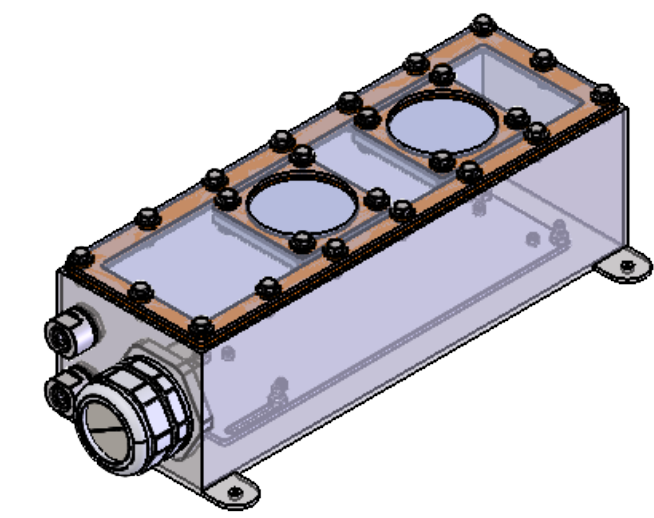
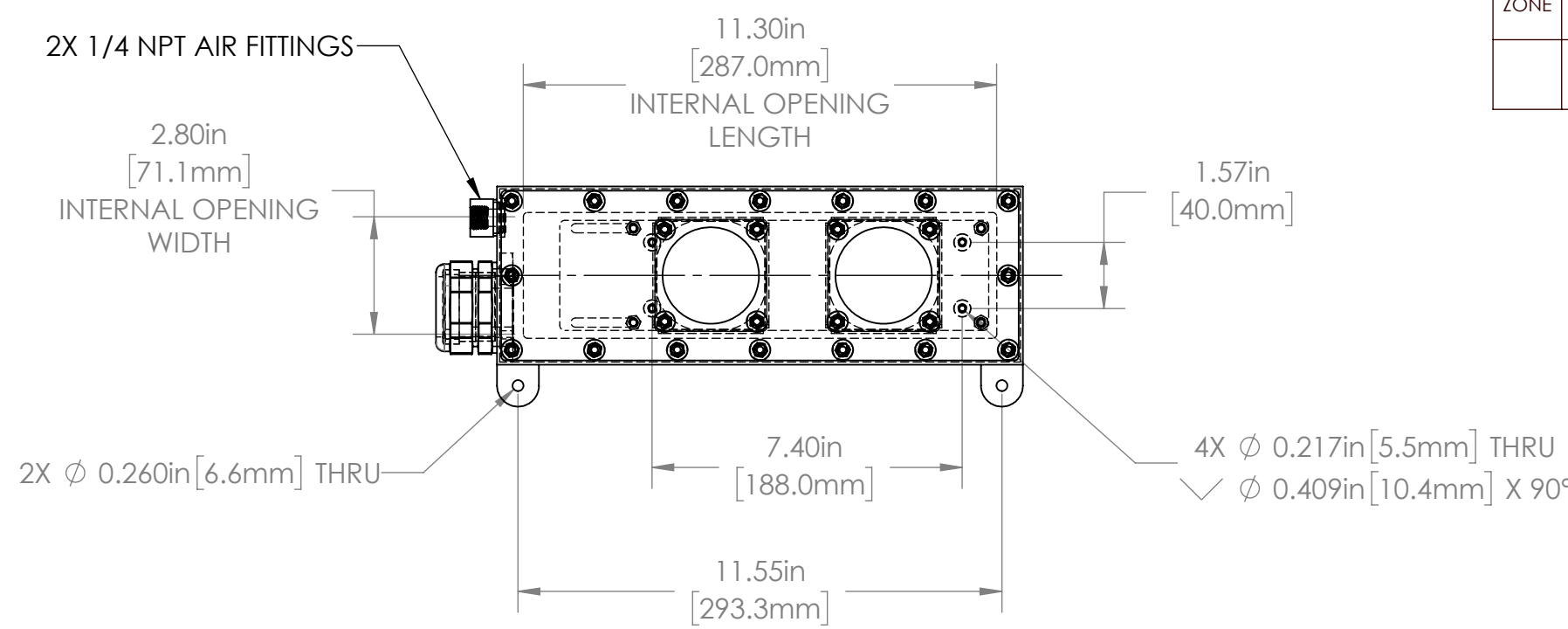

**LL SERIES PROPERTIES TABLE**

<b>ENVIRONMENT RATING</b>	IP68*	
	(*RATING MAY CHANGE IF INSTALLER MILLS CABLE GLAND OUTSIDE OF TOLERANCE)	
<b>COMPONENT</b>	<b>MATERIAL</b>	<b>FINISH</b>
BODY	316 SS	BURNISHED
VIEWPORT	CLAREX ACRYLIC	AR2
GASKET	SILICONE	NONE
ARM/ADAPTER	6061 ALUM	NONE
HARDWARE	316 SS - EXTERNAL, 18-8 SS - INTERNAL	AS SUPPLIED

TOLERANCES UNLESS OTHERWISE SPECIFIED

MACHINING		SHEET METAL	
X.X	0.0250"	HOLE TO HOLE (SAME SURFACE)	
X.XX	0.0100"	X.X	0.030"
X.XXX	0.0050"	X.XX	0.010"
X.XXXX	0.0005"	X.XXX	0.005"
ANGULAR	0.5°	HOLE TO FOLDED EDGE	
DEBURR ALL		X.X	0.035"
		X.XX	0.025"
		X.XXX	0.015"
		FOLD TO FOLD	
		X.X	0.045"
		X.XX	0.035"
		X.XXX	0.020"
		ANGULAR 1.0°	

THIS PRINT IS THE PROPERTY OF APG VISION LLC. THE INFORMATION CONTAINED HEREIN IS CONFIDENTIAL. IT IS NOT TRANSFERABLE. IT IS FURNISHED WITH THE CLEAR UNDERSTANDING THAT IT IS NOT TO BE TRACED, REPRODUCED OR USED IN ANY PROCESS OF MANUFACTURING WITHOUT WRITTEN PERMISSION FROM THE OWNER AND IS RETURNABLE UPON DEMAND. ANY INFRINGEMENT UPON THE PATENT RIGHTS SHOWN HEREIN, WHETHER IN PART OR WHOLE, WILL BE PROSECUTED.

AS PART OF OUR POLICY OF CONTINUING DEVELOPMENT, APG VISION LLC RESERVES THE RIGHT TO ALTER SPECIFICATIONS WITHOUT PRIOR NOTICE.

APG Vision LLC  
4055 Alpha Drive  
Allison Park, PA 15101 USA  
Phone +1 (412) 487-8211  
apgvision.com

**apgvision**

DESCRIPTION:  
**LL SERIES SEALED ENCLOSURE, CLAREX VIEWPORTS, AIR FITTINGS, GOCATOR 2140**

MATERIAL: **SEE PROPERTIES TABLE**

FINISH: **SEE PROPERTIES TABLE**

DRAWN BY: DMM	DATE: 3/1/2023	SCALE: 1:4	SHT-SIZE: B	APPROX. WEIGHT (LBS): 6.7914
CHECKED BY: DMM	DATE: 3/1/2023	PART NUMBER: <b>LL-FG</b>		REVISION: A

Sheet 1 of 1

1 2 3 4 5 6