

6 5 4 3 2 1

D

C

B

A

D

C

B

A

REVISIONS				
ZONE	REV.	DESCRIPTION	DATE	APPROVED
	A	RELEASED FOR PRODUCTION	3/7/2023	DMM

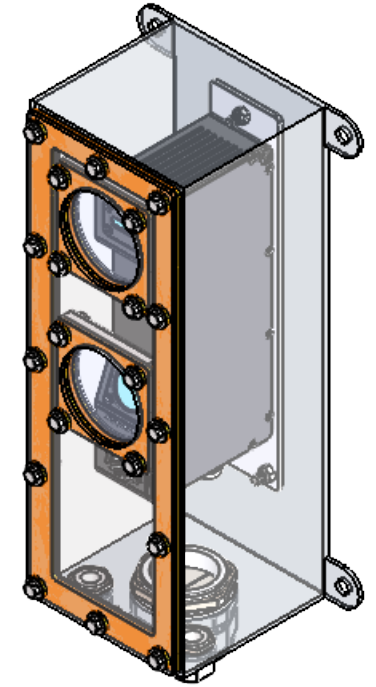
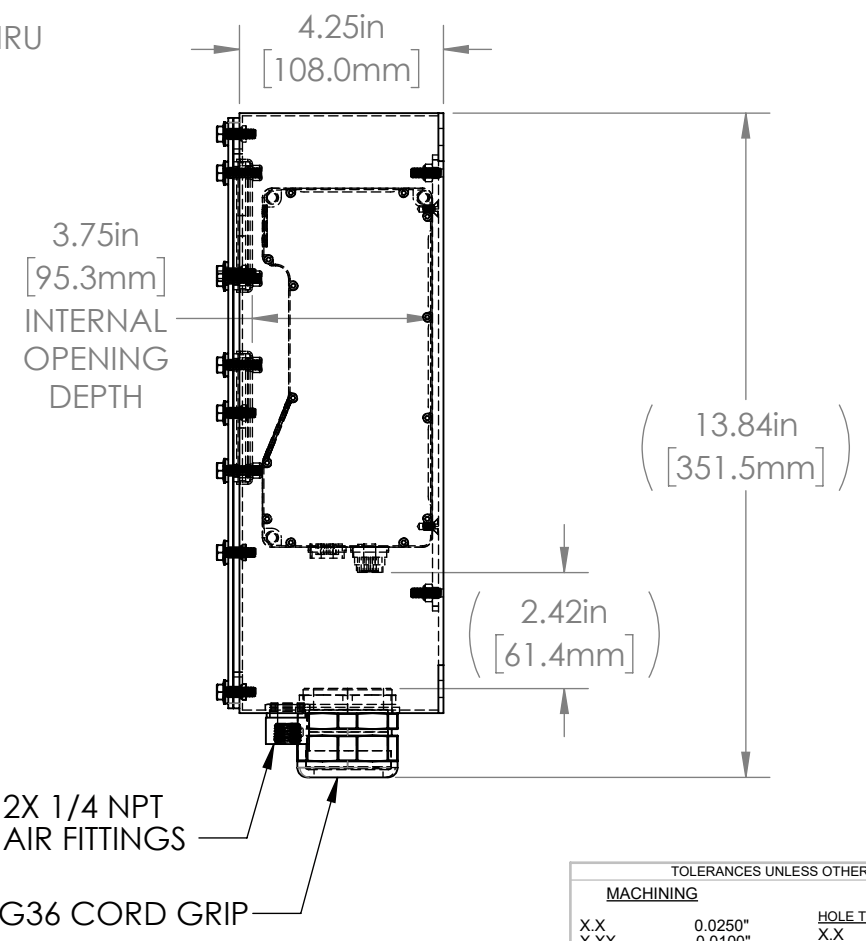
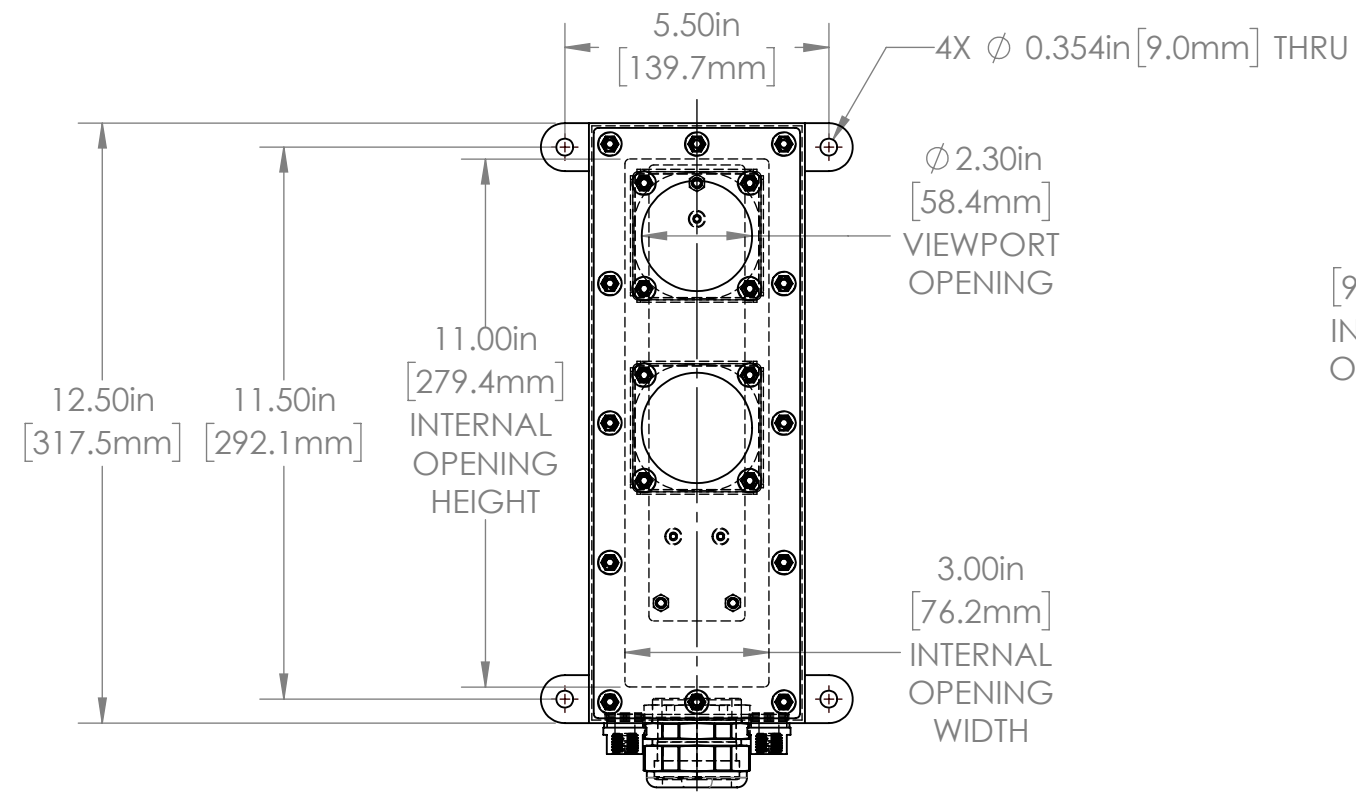
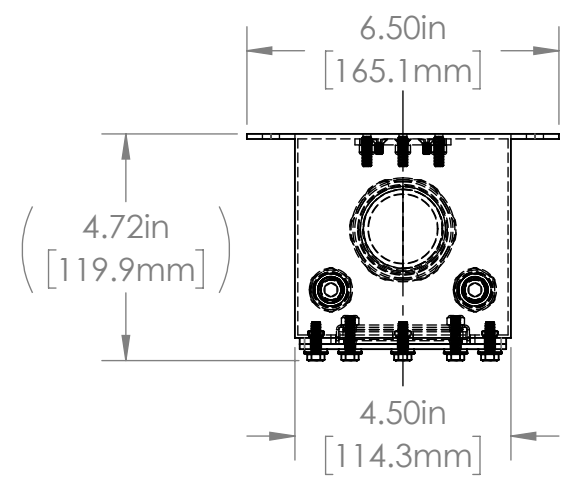

LL SERIES PROPERTIES TABLE

ENVIRONMENT RATING	IP68*	
	(*RATING MAY CHANGE IF INSTALLER MILLS CABLE GLAND OUTSIDE OF TOLERANCE)	
COMPONENT	MATERIAL	FINISH
BODY/LID	316 SS	BURNISHED
VIEWPORT	CLAREX ACRYLIC	AR2
GASKET	SILICONE	NONE
ARM/ADAPTER	6061 ALUMINUM	NONE
HARDWARE	316 SS - EXTERNAL, 18-8 SS - INTERNAL	NONE

TOLERANCES UNLESS OTHERWISE SPECIFIED

MACHINING		SHEET METAL	
X.X	0.0250"	HOLE TO HOLE (SAME SURFACE)	
X.XX	0.0100"	X.X	0.030"
X.XXX	0.0050"	X.XX	0.010"
X.XXXX	0.0005"	X.XXX	0.005"
ANGULAR	0.5°	HOLE TO FOLDED EDGE	
DEBURR ALL		X.X	0.035"
		X.XX	0.025"
		X.XXX	0.015"
		FOLD TO FOLD	
		X.X	0.045"
		X.XX	0.035"
		X.XXX	0.020"
		ANGULAR 1.0°	

THIS PRINT IS THE PROPERTY OF APG VISION LLC. THE INFORMATION CONTAINED HEREIN IS CONFIDENTIAL. IT IS NOT TRANSFERABLE. IT IS FURNISHED WITH THE CLEAR UNDERSTANDING THAT IT IS NOT TO BE TRACED, REPRODUCED OR USED IN ANY PROCESS OF MANUFACTURING WITHOUT WRITTEN PERMISSION FROM THE OWNER AND IS RETURNABLE UPON DEMAND. ANY INFRINGEMENT UPON THE PATENT RIGHTS SHOWN HEREIN, WHETHER IN PART OR WHOLE, WILL BE PROSECUTED.

AS PART OF OUR POLICY OF CONTINUING DEVELOPMENT, APG VISION LLC RESERVES THE RIGHT TO ALTER SPECIFICATIONS WITHOUT PRIOR NOTICE.

APG Vision LLC
4055 Alpha Drive
Allison Park, PA 15101 USA
Phone +1 (412) 487-8211
apgvision.com

apgvision

DESCRIPTION:
LL SERIES ENCLOSURE, CLAREX VIEWPORTS, AIR FITTINGS, FOR GOCATOR 2440

MATERIAL: **SEE BOM**

FINISH: **SEE BOM**

DRAWN BY:	DATE:	SCALE:	SHT-SIZE:	APPROX. WEIGHT (LBS)
GAS	3/7/2023	1:4	B	8.8931
CHECKED BY:	DATE:	PART NUMBER:	REVISION	
DMM	3/7/2023	LL-FK	A	

Sheet 1 of 1

6 5 4 3 2 1