

1 2 3 4 5 6

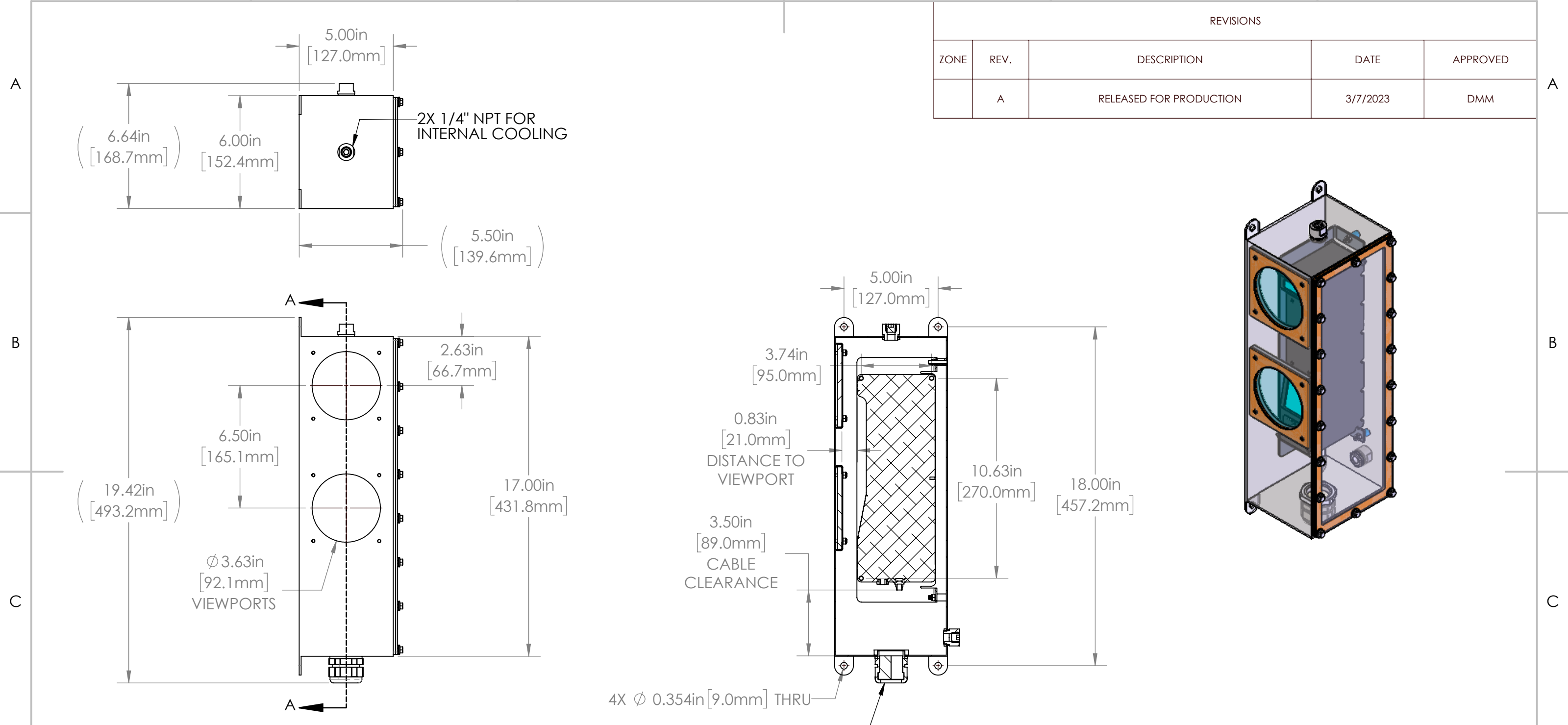

REVISIONS				
ZONE	REV.	DESCRIPTION	DATE	APPROVED
	A	RELEASED FOR PRODUCTION	3/7/2023	DMM

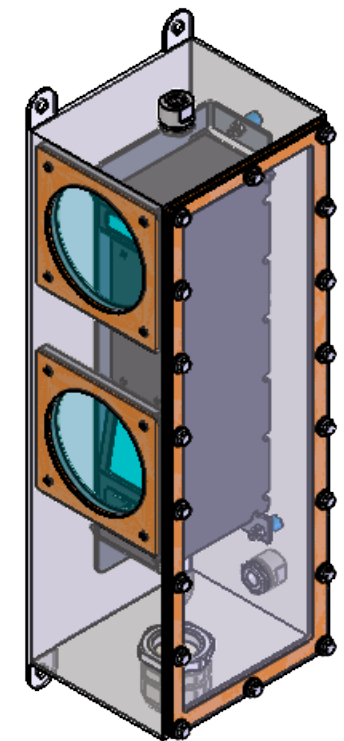

LL PROPERTIES TABLE		
<b>ENVIRONMENT RATING</b>	IP68*	FDA WASHDOWN
	(*RATING MAY CHANGE IF INSTALLER MILLS CABLE GLAND OUTSIDE OF TOLERANCE)	
<b>COMPONENT</b>	<b>MATERIAL</b>	<b>FINISH</b>
BODY/LID	316 SS	BURNISHED
VIEWPORT	CLEAR FLOWCOAT ACRYLIC	ABR2
GASKET	SILICONE	NONE
ARM/ADAPTER	5052 ALUMINUM	NONE
HARDWARE	316 SS - EXTERNAL, 18-8 SS - INTERNAL	AS SUPPLIED

TOLERANCES UNLESS OTHERWISE SPECIFIED

MACHINING	SHEET METAL
X.X 0.0250"	HOLE TO HOLE (SAME SURFACE)
X.XX 0.0100"	X.X 0.030"
X.XXX 0.0050"	X.XX 0.010"
X.XXXX 0.0005"	X.XXX 0.005"
ANGULAR 0.5°	HOLE TO FOLDED EDGE
DEBURR ALL	X.X 0.035"
	X.XX 0.025"
	X.XXX 0.015"
	FOLD TO FOLD
	X.X 0.045"
	X.XX 0.035"
	X.XXX 0.020"
	ANGULAR 1.0°

THIS PRINT IS THE PROPERTY OF APG VISION LLC. THE INFORMATION CONTAINED HEREIN IS CONFIDENTIAL. IT IS NOT TRANSFERABLE. IT IS FURNISHED WITH THE CLEAR UNDERSTANDING THAT IT IS NOT TO BE TRACED, REPRODUCED OR USED IN ANY PROCESS OF MANUFACTURING WITHOUT WRITTEN PERMISSION FROM THE OWNER AND IS RETURNABLE UPON DEMAND. ANY INFRINGEMENT UPON THE PATENT RIGHTS SHOWN HEREIN, WHETHER IN PART OR WHOLE, WILL BE PROSECUTED.

AS PART OF OUR POLICY OF CONTINUING DEVELOPMENT, APG VISION LLC RESERVES THE RIGHT TO ALTER SPECIFICATIONS WITHOUT PRIOR NOTICE.

APG Vision LLC  
4055 Alpha Drive  
Allison Park, PA 15101 USA  
Phone +1 (412) 487-8211  
apgvision.com

**apgvision**

DESCRIPTION:  
**LL ENCLOSURE WITH PG29 CORD GRIP & AIR COOLING FOR GOCATOR 2690**

MATERIAL: **SEE PROPERTIES TABLE**

FINISH: **SEE PROPERTIES TABLE**

DRAWN BY: GAS	DATE: 3/7/2023	SCALE: 1:5	SHT-SIZE: B	APPROX. WEIGHT (LBS): 21.2642
CHECKED BY: DMM	DATE: 3/7/2023	PART NUMBER: LL-FO	REVISION: A	

Sheet1 of 1

1 2 3 4 5 6