

REVISIONS				
ZONE	REV.	DESCRIPTION	DATE	APPROVED
	A	RELEASED FOR PRODUCTION	5/2/2023	DMM

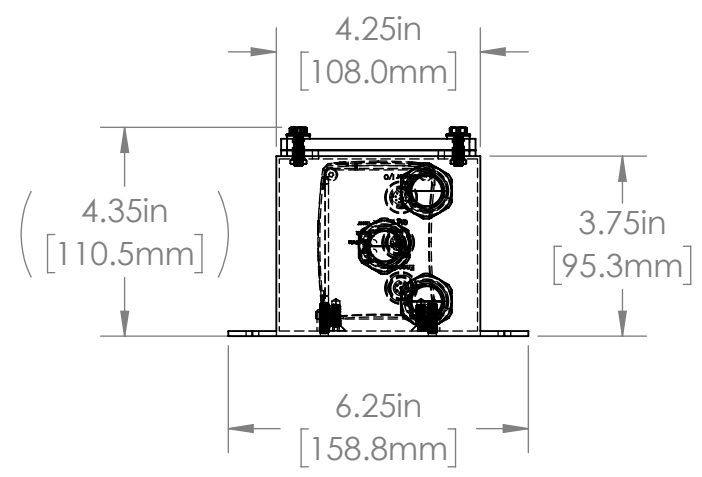
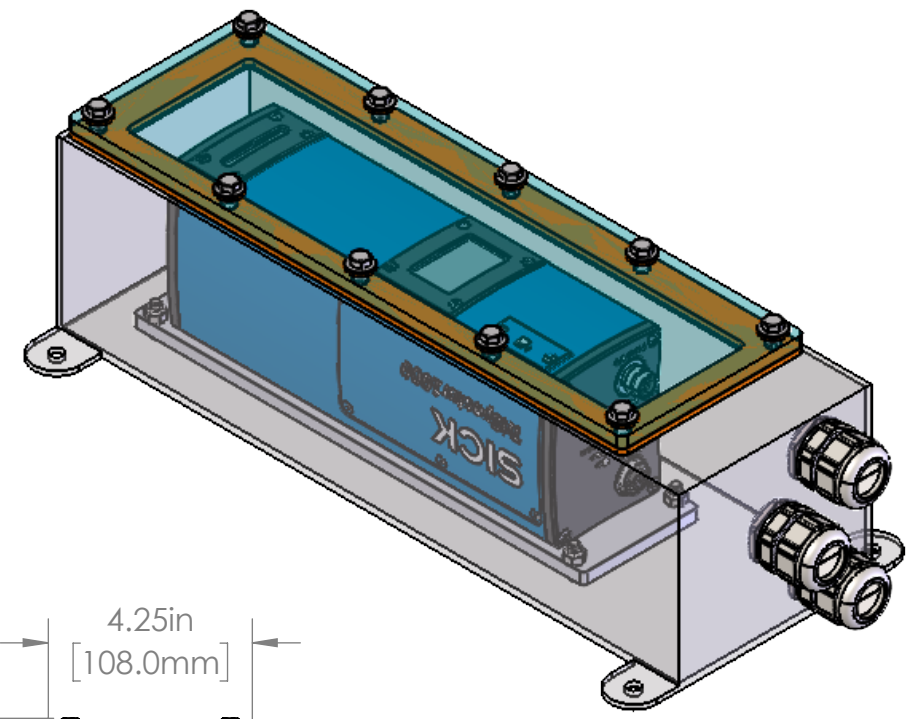

LL SERIES PROPERTIES TABLE

ENVIRONMENT RATING	IP69K*	FDA WASHDOWN
(*RATING MAY CHANGE IF INSTALLER MILLS CABLE GLAND OUTSIDE OF TOLERANCE)		
COMPONENT	MATERIAL	FINISH
BODY	316 SS	BURNISHED
VIEWPORT	CLEAR FLOWCOAT ACRYLIC	ABR2
GASKET	SILICONE	NONE
ARM	6061 ALUMINUM	NONE
HARDWARE	316 SS - EXTERNAL, 18-8 SS - INTERNAL	NONE

TOLERANCES UNLESS OTHERWISE SPECIFIED	
MACHINING	SHEET METAL
X.X 0.0250"	HOLE TO HOLE (SAME SURFACE) X.X 0.030"
X.XX 0.0100"	X.XX 0.010"
X.XXX 0.0050"	X.XXX 0.005"
X.XXXX 0.0005"	X.XXX 0.015"
ANGULAR 0.5°	HOLE TO FOLDED EDGE X.X 0.035"
DEBURR ALL	X.XX 0.025"
	X.XXX 0.015"
	FOLD TO FOLD X.X 0.045"
	X.XX 0.035"
	X.XXX 0.020"
	ANGULAR 1.0°

THIS PRINT IS THE PROPERTY OF APG VISION LLC. THE INFORMATION CONTAINED HEREIN IS CONFIDENTIAL. IT IS NOT TRANSFERABLE. IT IS FURNISHED WITH THE CLEAR UNDERSTANDING THAT IT IS NOT TO BE TRACED, REPRODUCED OR USED IN ANY PROCESS OF MANUFACTURING WITHOUT WRITTEN PERMISSION FROM THE OWNER AND IS RETURNABLE UPON DEMAND. ANY INFRINGEMENT UPON THE PATENT RIGHTS SHOWN HEREIN, WHETHER IN PART OR WHOLE, WILL BE PROSECUTED.

AS PART OF OUR POLICY OF CONTINUING DEVELOPMENT, APG VISION LLC RESERVES THE RIGHT TO ALTER SPECIFICATIONS WITHOUT PRIOR NOTICE.

APG Vision LLC
 4055 Alpha Drive
 Allison Park, PA 15101 USA
 Phone +1 (412) 487-8211
 apgvision.com

apgvision

DESCRIPTION:
LL ENCLOSURE FOR SICK TRISPECTOR 1030 WITH ADDED CABLE CLEARANCE

MATERIAL: **SEE BOM**

FINISH: **SEE BOM**

DRAWN BY: GAS	DATE: 5/2/2023	SCALE: 1:3	SHT-SIZE: B	APPROX. WEIGHT (LBS): 6.1107
CHECKED BY: DMM	DATE: 5/2/2023	PART NUMBER: LL-FU	REVISION: A	

Sheet1 of 1