

AP-3200T-USB-LSX

Technical Datasheet



See the possibilities

IMX265

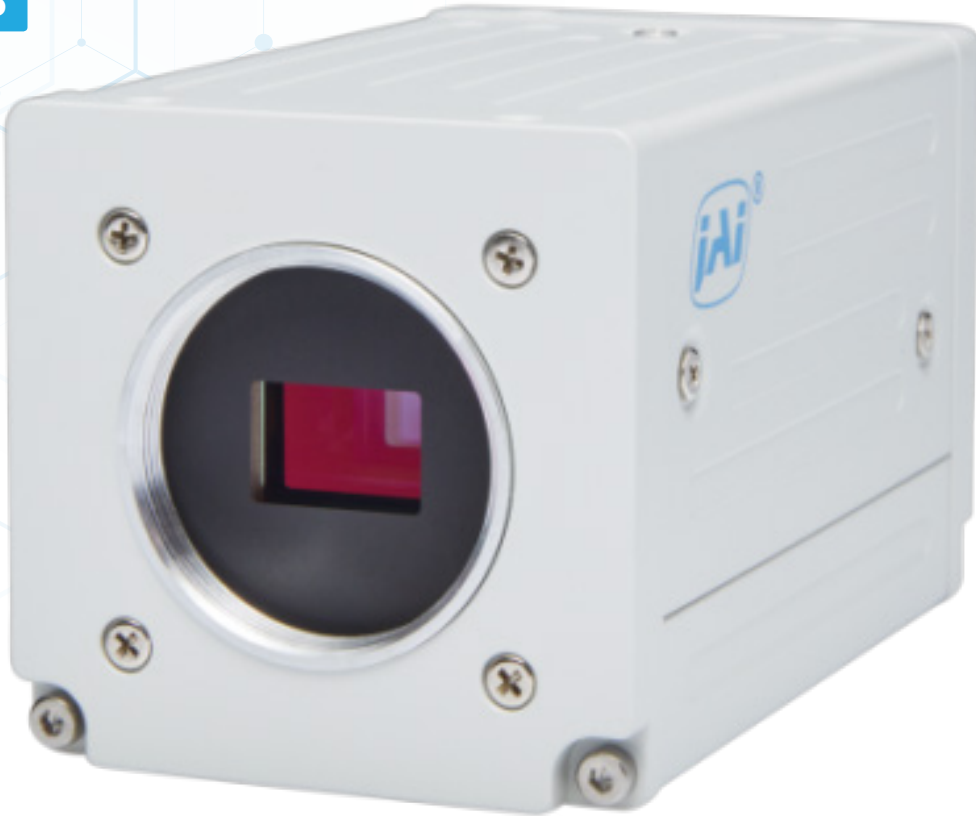

Apex Series

USBTM
VISION

Apex Medical & Life Sciences Solutions is a suite of 3-CMOS area scan cameras offering advanced color imaging capabilities for a wide range of applications in the medical and life sciences markets. The multi-sensor prism technology provides better color fidelity and spatial precision than traditional Bayer color cameras, while the USB3 Vision interface offers excellent plug-and-play compatibility.

All Apex Medical models are fully integrated with two of the most popular microscopy software solutions – Image-Pro® from Media Cybernetics and the μ Manager open source software package.

Specification Highlights

SENSOR:	IMX265	SHUTTER:	Global Shutter
FORMAT:	1/1.8"	FRAME RATE:	38 fps
PIXEL SIZE:	3.45 x 3.45 μ m	INTERFACE:	USB3 Vision (PoUSB)
LENS MOUNT:	C-Mount	RESOLUTION MP:	3.2 MP
SPECTRUM:	Color (Visible + NIR)	RESOLUTION WxH:	2064 x 1544 px

Specifications	AP-3200T-USB-LSX
Sensor	1/1.8" 3-CMOS global shutter (IMX265)
Active pixels	2064 (h) x 1544 (v) x 3 (R,G,B)
Frame rate, full frame	38.3 frames/sec. @ 8-bit
Active area	7.12 mm (h) x 5.33 mm (v) - 8.89 mm diagonal
Pixel size	3.45 μm x 3.45 μm
System clock	74.25 MHz (for pulse generator)
Read-out modes	
Full ROI (single)	2064 (h) x 1544 (v) up to 38.3 fps H: 16 to 2064 pixels in 16 pixel steps V: 2 to 1544 lines in 2 line steps
ROI (multi) Binning	Up to 5 overlapping scanning areas can be defined. 1x2, 2x1, 2x2
EMVA 1288 Parameters	12-bit output format
Absolute sensitivity	3.77 p (λ = 525 nm)
Maximum SNR	40.39 dB
Traditional SNR*	>60 dB (0 dB gain, 10-bit)
Video signal output	8/10/12-bits per channel [†] (24/30/36-bit RGB)
Video modes	Normal, Single ROI, Multi ROI, Sequencer
Gain	Manual control - master mode or individual R/G/B channels Auto gain control - off, continuous, one-push
White balance	Off, 4 presets (3200K, 5000K, 6500K, 7500K), or one-push/continuous AWB using gain or exposure time (3000K to 9000K)
Gamma/LUT	0.45 to 1.0 (9 steps) or 257-point programmable LUT
Shading correction	Flat shading, color shading
Trigger input	Opto In (2), Pulse Generators (4), Software, NAND Out (2), User Output (4)
Exposure modes	Timed/EPS, Trigger Width, Auto
Electronic shutter	(can be set independently for R/G/B channels) 30.73 μs to 8 sec. in 1 μs steps (8-bit) 34.73 μs to 8 sec. in 1 μs steps (10-bit)
Auto Level Control (ALC)	Shutter range from 100 μs to 13.427 ms, gain range from 0 dB to +12 dB. Tracking speeds and max. values adjustable.
Pre-processing functions	Color enhancer, edge enhancer, color space conversion (RGB to HSI, XYZ, sRGB, Adobe RGB), blemish compensation (200 px/channel)
Operating temp. (ambient)	-5°C to +45°C (20 to 80% non-condensing)
Storage temp. (ambient)	-25°C to +60°C (20 to 80% non condensing)
Vibration	3G (20 Hz to 200 Hz, XYZ directions)
Shock	50G
Regulations	CE (EN61000-6-2, EN61000-6-3) FCC Part 15 Class B, RoHS/WEEE
Power	+12V to +24V DC ± 10%. 5.3 W typical @ +12 V
I2-pin USB 3.0	Bus power: not supported
Lens mount	C-mount
Dimensions (H x W x L)	44 mm x 44 mm x 74 mm (excl. connectors)
Weight	170 g
Ordering Information	
AP-3200T-USB-LSX	3-CMOS prism color camera with USB3
AP-3200T-USB-NF-LSX	Vision Same as above with IR-cut filter removed

*Traditional SNR is based on random noise in a single frame, where EMVA SNR measurements consider more comprehensive noise sources and variance over time.

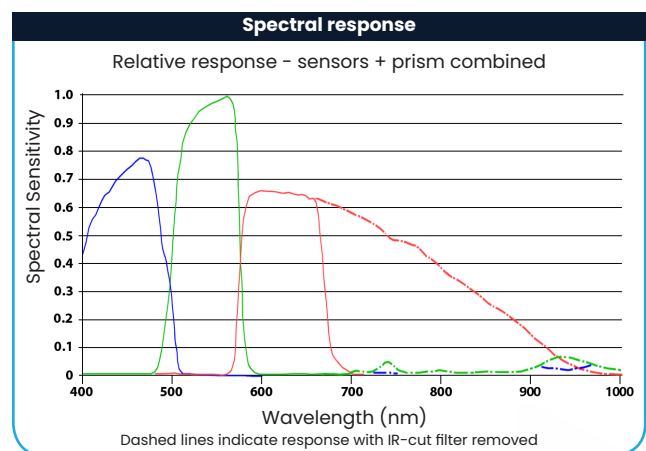
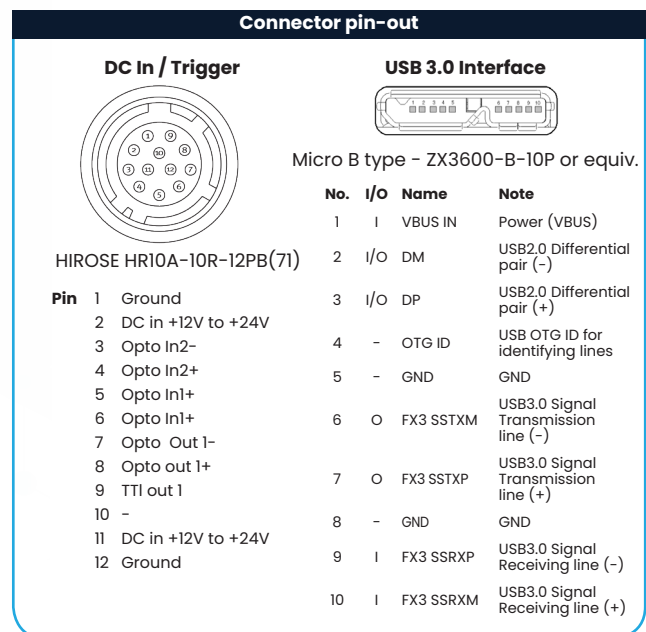
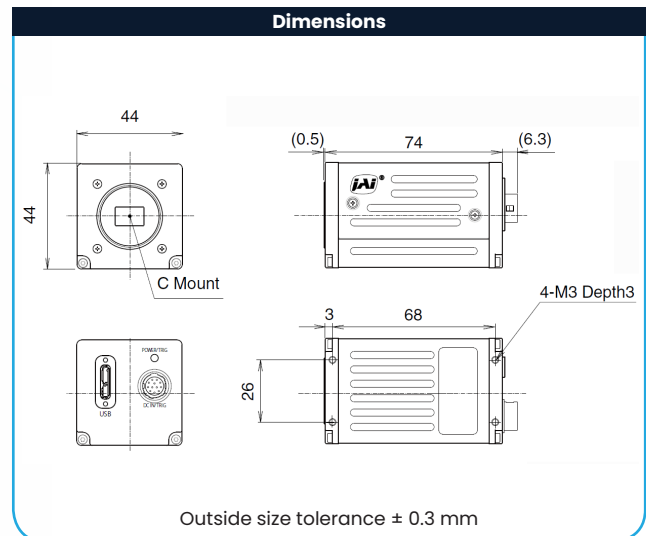

[†]12-bit output available in video processing bypass mode. See manual for details.

Product Highlights

- High resolution prism-based 3CMOS camera
- Full spatial resolution and true RGB color values with no interpolation
- Pre-screened to meet strict quality standards for dust/FODs in imaging path
- Available with or without IR-cut filter for applications needing extended red/NIR response
- Individual analog gain and exposure control for R, G, and B channels
- Color and edge enhancement functions
- On-board RGB to HSI, XYZ, sRGB and Adobe RGB color space conversions
- Single and multi-ROI's
- RGB video output with 8, 10, or 12-bits per channel*
- Compact size and white housing designed for clinical/laboratory environments
- Excellent shock and vibration resistance
- USB3 Vision interface
- C-mount lens mount

* Some video processing functions not available with 12-bit output

Additional Product Images



Company and product names mentioned in this datasheet are trademarks or registered trademarks of their respective owners.

JAI A-S and Machine Vision Direct, LLC Cannot be held responsible for any technical or typographical errors and reserves the right to make changes to products and documentation without prior notice