

GO-5100MP-USB

Technical Datasheet



See the possibilities

IMX250MZR



Apex Series

USBTM
VISION

JAI's Go Series delivers an exceptional blend of small size, high versatility, and excellent performance, all at an entry-level price, making the cameras a perfect starting point for a wide range of machine vision applications.

CMOS technology, low-noise pixels, global shutters, sequencer functions, and other advanced features help ensure image quality and operational flexibility beyond entry-level expectations.

Specification Highlights

SENSOR:	IMX250MZR	SHUTTER:	Global Shutter
FORMAT:	2/3"	FRAME RATE:	74 fps
PIXEL SIZE:	3.45 x 3.45 μ m	INTERFACE:	USB3 Vision (PoUSB)
LENS MOUNT:	C-Mount	RESOLUTION MP:	5.1 MP
SPECTRUM:	Monochrome Polarized (Visible)	RESOLUTION WxH:	2464 x 2056 px

Specifications	GO-5100MP-USB
Sensor	2/3" CMOS global shutter (IMX250MZR)
Active pixels	2464 (h) x 2056 (v)
Frame rate, full frame	74 frames/sec. @ 8-bit
Active area	8.5 mm (h) x 7.09 mm (v) - 11.1 mm diagonal
Pixel size	3.45 μm x 3.45 μm
System clock	74.25 MHz (for pulse generator)
Read-out modes	
Full ROI (single)	2464 (h) x 2056 (v) up to 74 fps H: 16 to 2464 pixels in 16 pixel steps V: 2 to 2056 lines in 2 line steps
Binning	1x2, 2x1, 2x2
EMVA 1288 Parameters	10-bit output format
Absolute sensitivity	TBD p (λ = 525 nm)
Maximum SNR	SNR dB
Traditional SNR*	>60 dB (0 dB gain, 10-bit)
Video signal output	8/10/12-bit monochrome
Video modes	Normal, Single ROI, Multi ROI, Sequencer, Delayed Readout
Gain	Manual/auto 0 dB to +24 dB
Gamma	0.45 to 1.0 (9 steps)
Shading correction	Flat shading
Blemish compensation	256 pixels
256 pixels	Opto In (1), Pulse Generator, Software, NAND Out (2), Action (2)
Exposure modes	Timed/EPS, Trigger Width, Auto
Electronic shutter	Timed: 14.7 μs to 8 sec. in 1 μs steps Trigger Width: 14.7 μs to ∞ sec. in 1 μs steps
Auto Level Control (ALC)	Shutter range from 100 μs to 13.427 ms, gain range from 0 dB to +24 dB. Tracking speeds and max. values adjustable.
Pre-processing functions	Polarization angle, polarization ratio, polarized light only, diffused light only, average light, pseudo color over monochrome, pseudo color over gray image
Operating temp. (ambient)	-5°C to +45°C (20 to 80% non-condensing)**
Storage temp. (ambient)	-25°C to +60°C (20 to 80% non condensing)
Vibration	10G (20 Hz to 200 Hz, XYZ directions)
Shock	80G
Regulations	CE (EN61000-6-2, EN61000-6-3) FCC Part 15 Class B, RoHS/WEEE
Power	6-pin USB 3.0 +12V to +24V DC ± 10%. 4.2 W typical @ +12 V +5V DC. 4.35 W typical @ +5 V
Lens mount	C-mount
Dimensions (H x W x L)	29 mm x 29 mm x 41.5 mm (excl. lens mount)
Weight	46 g
Ordering Information	
GO-5100MP-USB	Monochrome polarization camera with USB3 Vision

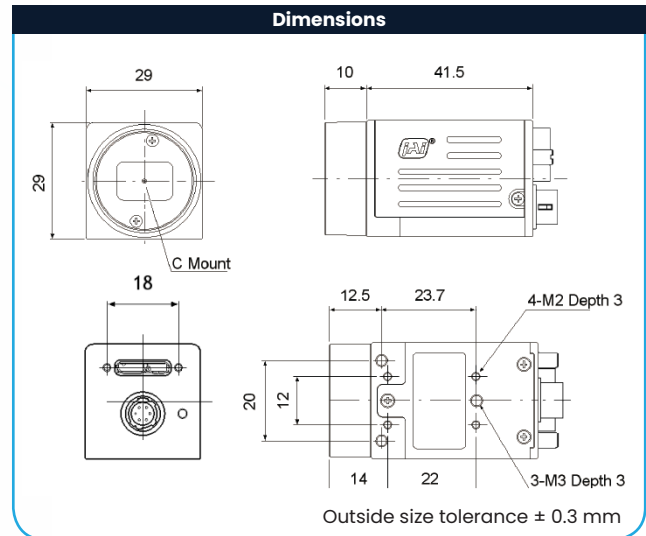

Connector pin-out

DC In / Trigger

HIROSE HR10A-7R-6PB(73)

Pin	Signal
1	DC in +12V to +24V
2	Opto In 1
3	Opto Out 1
4	Opto Out 2
5	Opto Common
6	GND

USB 3.0 Interface

Micro B type - ZX3600-B-10P or equiv.

No	I/O	Name	Note
1	I	VBUS IN	Power (VBUS)
2	I/O	DM	USB2.0 Differential pair (-)
3	I/O	DP	USB2.0 Differential pair (+)
4	-	OTG ID	USB OTG ID for identifying lines
5	-	GND	GND
6	O	FX3 SSTXM	USB3.0 Signal Transmission line (-)
7	O	FX3 SSTXP	USB3.0 Signal Transmission line (+)
8	-	GND	GND
9	I	FX3 SSRXP	USB3.0 Signal Receiving line (-)
10	I	FX3 SSRXM	USB3.0 Signal Receiving line (+)

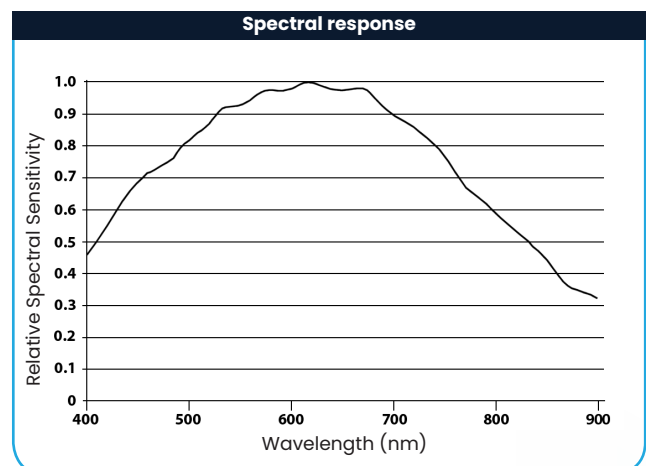

*Traditional SNR is based on random noise in a single frame, where EMVA SNR measurements consider more comprehensive noise sources and variance over time.

[†]12-bit output available in video processing bypass mode. See manual for details.

**Performance may be affected if temperature of camera exceeds 65°C (internal) or 61°C (top surface). See specifications section of manual for details.

Product Highlights

- 5.1-megapixel camera featuring Sony IMX250MZR CMOS polarized sensor
- Four different polarizing filters (0°, 45°, 90°, 135°) applied to each 4-pixel block
- Outputs raw 5.1 MP mosaic image or decimated images from each polarizing angle
- Built-in functions to calculate polarization angle, ratio, and appearance with diffuse light removed
- Additional functions display diffuse light only (without polarization) and average for each pixel
- Advanced algorithms provide pseudo-color overlay data for easier analysis
- 8, 10, or 12-bit monochrome output*
- Compact size and smart design
- Excellent shock and vibration resistance
- USB3 Vision interface
- C-mount lens mount
- Automatic Level Control (ALC) for dynamic lighting conditions

* Some video processing functions not available with 12-bit output

Additional Product Images



Company and product names mentioned in this datasheet are trademarks or registered trademarks of their respective owners.

JAI A-S and Machine Vision Direct, LLC Cannot be held responsible for any technical or typographical errors and reserves the right to make changes to products and documentation without prior notice