

GOX-20405C-5GE

Technical Datasheet



See the possibilities

IMX541 Pregius S



Apex Series



The Go-X Series offers compact, attractively-priced area scan cameras with a blend of features, image quality and industrial grade reliability that is in high demand for the next generation of machine vision systems.

The Go-X Series incorporates the most popular Sony Pregius and Pregius S global shutter CMOS sensors, and several Starvis CMOS sensors with rolling shutter technology. Resolutions range from 2.3 to 24.5 megapixels with a choice of USB3 Vision, GigE Vision (1000BASE-T or 5GBASE-T), or CoaXPress interfaces.

Specification Highlights

SENSOR: IMX541 Pregius S
FORMAT: 1.1"
PIXEL SIZE: 2.74 x 2.74 μm
LENS MOUNT: C-Mount
SPECTRUM: Color (Visible)

SHUTTER: Global Shutter
FRAME RATE: 27 fps
INTERFACE: 5 Gbps GigE Vision
RESOLUTION MP: 20.3 MP
RESOLUTION WxH: 4512 x 4512 px

Specifications	GOX-20405-5GE
Sensor	1.1" CMOS global shutter (IMX541)
Active pixels	4512 (h) x 4512 (v)
Frame rate, full frame	27 frames/sec. @ 8-bit mono/Bayer
Active area	12.4 mm (h) x 12.4 mm (v) - 17.48 mm diagonal
Pixel size	2.74 μm x 2.74 μm
Read-out modes	
Full ROI (single)	4512 (h) x 4512 (v) up to 27 fps H: 96 to 4512 pixels in 8 pixel steps V: 8 to 4512 lines in 2 line steps
ROI (multi)	Up to 64 scanning areas - no overlap
Binning	1x2, 2x1, 2x2 (mono only)
Image scaling (Xscale)	Supports independent, sub-pixel rescaling of H and/or V resolution (1/16 max.)
EMVA 1288 Parameters	10-bit output format
Absolute sensitivity	Mono: TBD p Color: TBD p ($\lambda = 527 \text{ nm}$)
Maximum SNR	Mono: TBD dB Color: TBD dB
Traditional SNR (Dark)*	>60 dB mono, >60 dB color (0 dB gain, 10-bit)
Video signal output	Monochrome: 8/10/12-bits Color: 8/10/12-bit Bayer or 24/32-bit RGB
Gain	Manual/auto 0 dB to +42 dB
White balance	Off, presets, or one-push/continuous AWB
Gamma/LUT	0.45 to 1.0 (9 steps) or 257-point programmable LUT
Time synchronization	Support for Precision Time Protocol (IEEE 1588)
Trigger input	Opto In, Pulse Generators (4), Software, NAND Out (2), User Output (4), Actions
Exposure modes	Timed/EPS, RCT, Trigger Width, Auto
Electronic shutter	Timed: 3.45 μs to 8 sec. in 1 μs steps Auto: 100 μs to 37 ms at full resolution
Auto Level Control (ALC)	Shutter range from 100 μs to 37 ms, gain range from 0 dB to +42 dB. Tracking speeds and min/max values adjustable.
Shading correction	Flat shading, color shading (color model)
Video processing functions	H & V flip (mirroring), blemish compensation, edge enhancement, color conversion (color model)
Operating temp. (ambient)	-5°C to +45°C (20 to 80% non-condensing)
Storage temp. (ambient)	-25°C to +60°C (20 to 80% non condensing)
Vibration	10G (20 Hz to 200 Hz, XYZ directions)
Shock	80 G
Regulations	CE (EN 55032:2015 (CISPR32:2015), EN 55035:2017 (CISPR35:2016)), FCC Part 15 Class A, RoHS/WEEE, KC
Power	6-pin PoE +10V to +25V DC. 5.1 W typical @ +12 V +36V to +57 V DC. 6.7 W typical @ +48 V
Lens mount	C-mount
Dimensions (H x W x L)	29 mm x 29 mm x 68 mm
Weight	95 g
Ordering Information	
GOX-20405M-5GE	Monochrome camera with 5GigE Vision interface
GOX-20405C-5GE	Color camera with 5GigE Vision interface

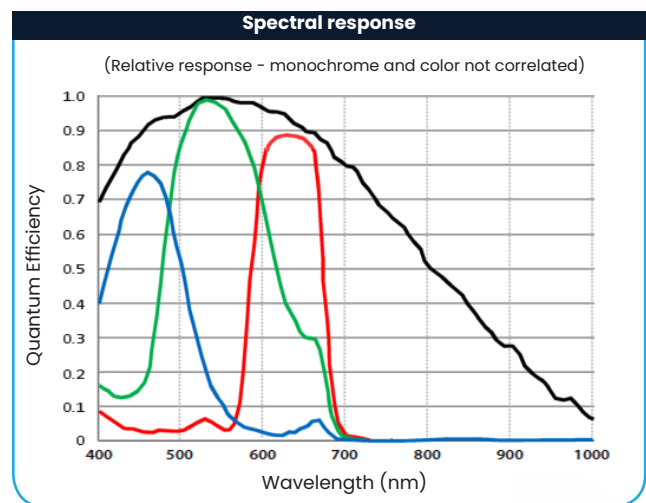
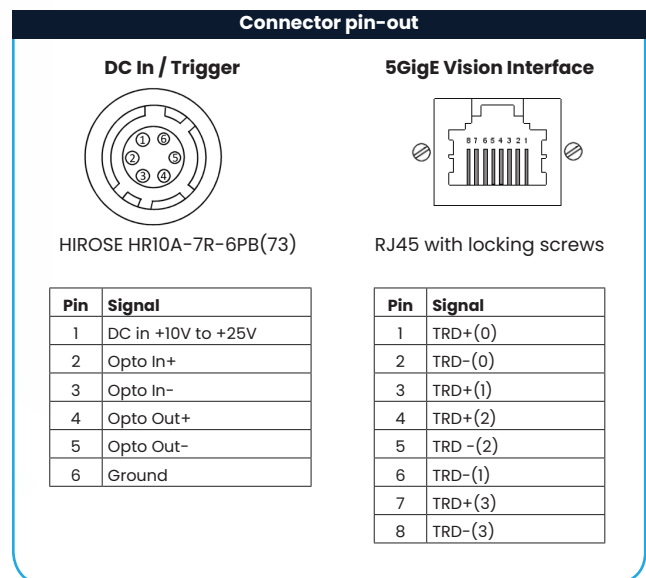
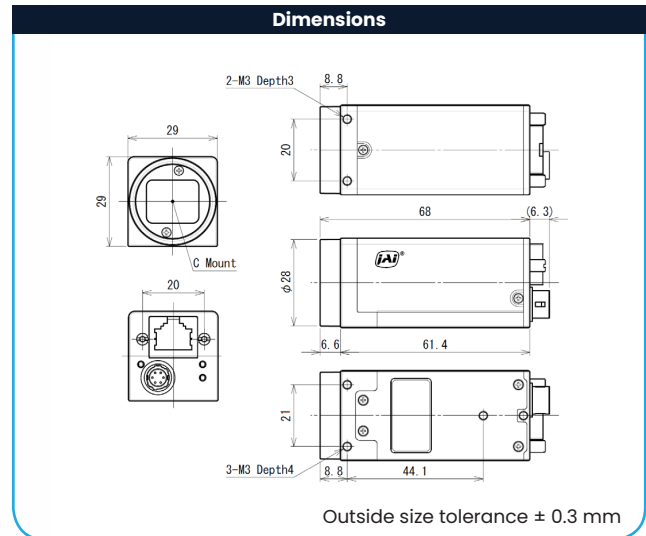

*Traditional SNR is based on random noise in a single frame, where EMVA SNR measurements consider more comprehensive noise sources and variance over time.

Product Highlights

- High performance camera with 20.3-megapixel resolution
- 1.1" CMOS imager (global shutter) features backside illuminated pixel technology
- 4512 x 4512 resolution with 2.74 μm square pixels
- Up to 27 fps over high performance 5GBASE-T interface (5 gigabits per second)
- Can auto-negotiate to 2.5GBASE-T and standard GigE (1000BASE-T)
- 8/10/12-bit output in choice of monochrome or raw Bayer color models
- Flexible ROI & rescaling function (Xscale) for sub-pixel color/mono binning and resolution matching
- Traditional 1x2, 2x1, or 2x2 binning also included on monochrome models
- Horizontal/vertical image flip function, plus blemish compensation and shading correction
- Bayer model includes 5x5 debayering function plus built-in color conversion and temperature presets
- Includes Sequencer function and Automatic Level Control (ALC) for dynamic lighting conditions
- Compact size with excellent shock and vibration resistance
- Accepts power over GigE Vision interface or via separate 6-pin connector
- C-mount lens mount

Additional Product Images

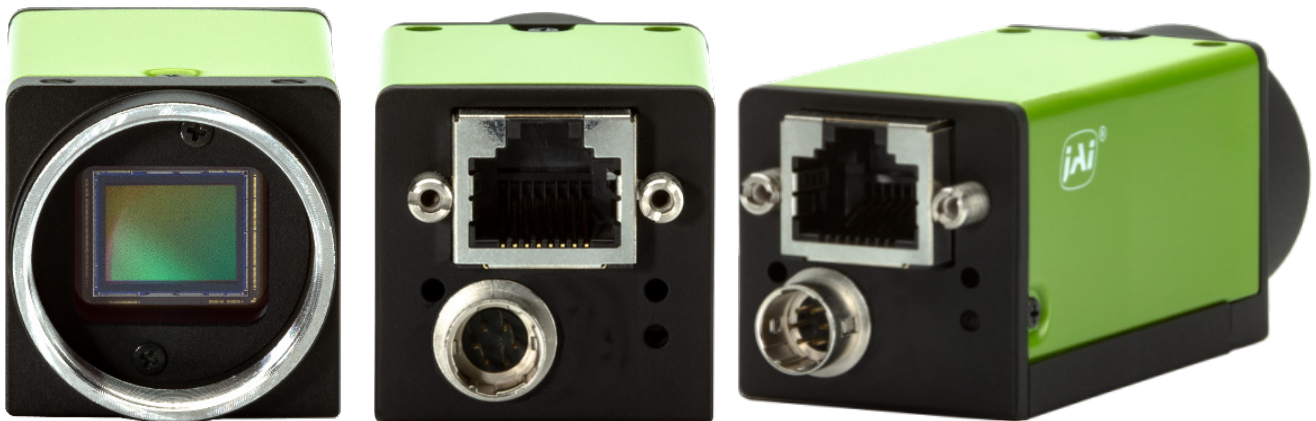

Company and product names mentioned in this datasheet are trademarks or registered trademarks of their respective owners.

JAI A-S and Machine Vision Direct, LLC Cannot be held responsible for any technical or typographical errors and reserves the right to make changes to products and documentation without prior notice