

GOX-6409C-PGE

Technical Datasheet



See the possibilities

IMX178 (Rolling)



Apex Series



The Go-X Series offers compact, attractively-priced area scan cameras with a blend of features, image quality and industrial grade reliability that is in high demand for the next generation of machine vision systems.

The Go-X Series incorporates the most popular Sony Pregius and Pregius S global shutter CMOS sensors, and several Starvis CMOS sensors with rolling shutter technology. Resolutions range from 2.3 to 24.5 megapixels with a choice of USB3 Vision, GigE Vision (1000BASE-T or 5GBASE-T), or CoaXPress interfaces.

Specification Highlights

SENSOR:	IMX178 (Rolling)	SHUTTER:	Global Shutter
FORMAT:	1/1.8"	FRAME RATE:	18 fps
PIXEL SIZE:	2.4 x 2.4 μm	INTERFACE:	GigE Vision 1-Cable (PoE)
LENS MOUNT:	C-Mount	RESOLUTION MP:	6.3 MP
SPECTRUM:	Monochrome (Visible + NIR)	RESOLUTION WxH:	3088 x 2064 px

Specifications		GOX-6409-PGE
Sensor	1/1.8" CMOS rolling shutter (IMX178)	
Active pixels	3088 (h) x 2064 (v)	
Frame rate	18 frames/sec. @ 8-bit mono/Bayer	
Active area	7.37 mm (h) x 4.91 mm (v) - 8.86 mm diagonal	
Pixel size	2.4 μm x 2.4 μm	
System clock	74.25 MHz (for pulse generator)	
Read-out modes		
Full ROI (single)	3088 (h) x 2064 (v) up to 18 fps H: 96 - 3088 pixels in 16-pixel steps V: 8 to 2064 lines in 2-line steps	
Binning	1x2, 2x1, 2x2 (mono only)	
EMVA 1288 Parameters	8-bit output format	
Absolute sensitivity	Mono: TBD p Color: TBD p (λ = 527 nm)	
Maximum SNR	Mono: TBD dB Color: TBD dB	
Traditional SNR*	>60 dB mono, >60 dB color (0 dB gain, 10-bit)	
Video signal output	Monochrome: 8-bit Color: 8-bit Bayer	
Gain control	Manual/auto 0 dB to +42 dB	
White balance	Off, presets, or one-push/continuous AWB	
Gamma/LUT	0.45 to 1.0 (9 steps) or 257-point programmable LUT	
Synchronization	Internal	
Video modes	Normal/Single ROI	
Trigger input	Opto In, Pulse Generator, Software, NAND Out (2), User Output (4)	
Exposure modes	Timed/EPS, Auto	
Electronic shutter (TriggerMode OFF)	Timed: 16.02 μs to 1.7 s in 1 μs steps Auto: 100 μs to 55.5 ms at full resolution	
Auto Level Control (ALC)	Shutter range from 100 μs to 55.5 ms, gain range from 0 dB to +42 dB. Tracking speeds and max. values adjustable.	
Shading correction	Flat shading, color shading (color model)	
Pre-processing functions	H & V flip (mirroring), blemish compensation	
Operating temp. (ambient)	-5°C to +45°C (20 to 80% non-condensing)	
Storage temp. (ambient)	-25°C to +60°C (20 to 80% non condensing)	
Vibration	10G (20 Hz to 200 Hz, XYZ directions)	
Shock	80G	
Regulations	CE (EN 55032:2015 (CISPR32:2015), EN 55035:2017 (CISPR35:2016)), FCC Part 15 Class A, RoHS/WEEE, KC	
Power	6-pin PoE	+10V to +25V DC. 2.7 W typical @ +12 V +36V to +57 V DC. 3.7 W typical @ +48 V
Lens mount	C-mount	
Dimensions (H x W x L)	29 mm x 29 mm x 51.5 mm	
Weight	65 g	
Ordering Information		
GOX-6409M-PGE	Monochrome camera with GigE Vision interface	
GOX-6409C-PGE	Color camera with GigE Vision interface	

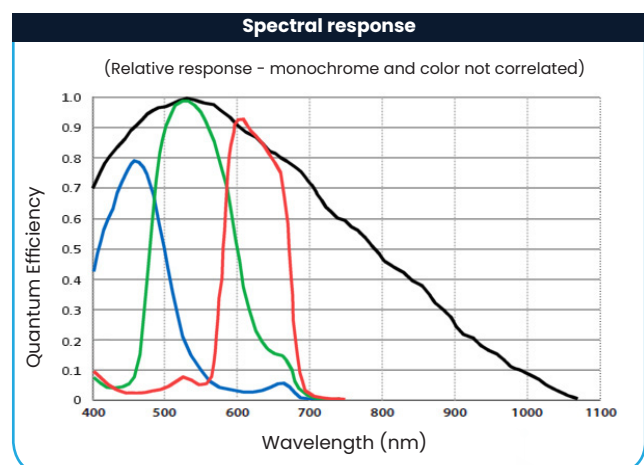
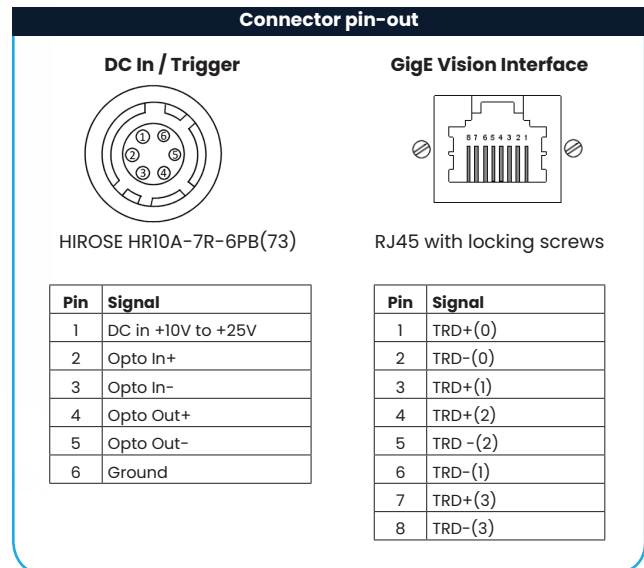
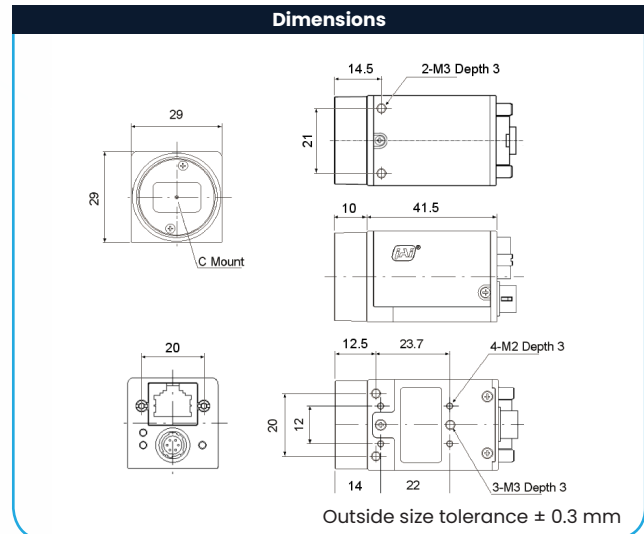

*Traditional SNR is based on random noise in a single frame, where EMVA SNR measurements consider more comprehensive noise sources and variance over time.

Product Highlights

- 1/1.8" CMOS imager (rolling shutter with global reset)
- Up to 18 fps at full resolution (3088 x 2064)
- 2.4 μm square pixels
- Backside illuminated (BSI) sensor technology for enhanced low-light performance
- 8-bit output in choice of monochrome or raw Bayer color models
- ROI settings for added flexibility
- Horizontal/vertical image flip function, plus blemish correction and shading compensation
- Includes Automatic Level Control (ALC) to maintain exposure in dynamic lighting conditions
- Compact size with excellent shock and vibration resistance
- Accepts power over GigE Vision interface or separate 6-pin connector
- C-mount lens mount

Additional Product Images



Company and product names mentioned in this datasheet are trademarks or registered trademarks of their respective owners.

JAI A-S and Machine Vision Direct, LLC Cannot be held responsible for any technical or typographical errors and reserves the right to make changes to products and documentation without prior notice