

SP-5000M-CXP4

Technical Datasheet



See the possibilities

Lince5M



Apex Series



Spark Series area scan cameras are the perfect choice for machine vision applications demanding high quality images with the highest possible throughput. They feature the latest CMOS imagers delivering high resolution images at speeds as much as 10 times faster than traditional CCD cameras.

For example, 45-megapixel (MP) models can deliver over 50 fps output while some 5-MP models run at 250 fps or more. Using the region-of-interest (ROI) feature, even higher frame rates can be achieved.

Specification Highlights

SENSOR:	Lince5M	SHUTTER:	Global Shutter
FORMAT:	1"	FRAME RATE:	253 fps
PIXEL SIZE:	5.0 x 5.0 μm	INTERFACE:	CoaxPress-4-Cable (PoCXP)
LENS MOUNT:	C-Mount	RESOLUTION MP:	5 MP
SPECTRUM:	Monochrome (Visible + NIR)	RESOLUTION WxH:	2560 x 2048 px

Specifications		SP-5000-CXP4
Sensor		1" CMOS global shutter
System clock		72 MHz (for pulse generator)
Frame rate, full frame		253 frames/sec. @ 8/10/12-bit, CXP6_X4
Active area		12.8 mm (h) x 10.2 mm (v), 16.39 mm diagonal
Cell size		5.0 μm (h) x 5.0 μm (v)
Active pixels		2560 (h) x 2048 (v)
Read-out modes		
Full ROI		2560 (h) x 2048 (v) up to 253 fps Any start line, any height in 2 line steps, with X offset and width in 64 pixel steps
Binning		1x2, 2x1, 2x2 (monochrome only)
Color interpolation (SP-5000C)		24-bit RGB output at up to 53 fps
EMVA 1288 Parameters		10-bit output format
Absolute sensitivity (mono)		23.50 p (λ = 525 nm)
Absolute sensitivity (color)		36.08 p (λ = 525 nm)
Maximum SNR (mono)		41.48 dB
Maximum SNR (color)		38.00 dB
Traditional SNR*	mono	>55 dB (0 dB gain)
	color	>53 dB (0 dB gain, green)
Video signal output	mono	8/10/12-bit monochrome
	color	8/10/12-bit Bayer or 24-bit RGB
Interface		CoaXPress v1.0 (CXP-6, DIN 1.0/2.3 connectors) Link Configs: CXP6_X4, CXP6_X2, CXP6_X1, CXP3_X4, CXP3_X2, CXP3_X1
Gain		Manual/automatic 0 dB to +24 dB
White balance (SP-5000C)		Manual, one-push auto, or continuous (3000K to 9000K)
Gamma		0.45-1.0 (16 steps) or 256-point LUT
Synchronization		Internal
Trigger input		TTL, CXP, Pulse Generators (4), Software, NAND Out (2), GPIO
Trigger modes		EPS, PIV, Trigger Width, Timed RCT (with ALC), Sequence
Electronic shutter		
Timed exposure		10 μs to 8 sec in 1 μs steps
Auto shutter		1/250 to 1/100000 sec.
Auto Level Control (ALC)		Shutter range from 1/253 to 1/100000, gain range from 0 dB to +24 dB, auto iris control Tracking speeds and max values adjustable.
Pre-processing functions		Flat field correction, color shading correction (SP-5000C), blemish compensation (512 pixels)
3-axis control		Programmable control of motorized lenses, pan/tilt heads, and other analog accessories
Operating temperature		-45°C to +70°C†
Storage temperature		-45°C to +70°C
Humidity		20 - 80% non-condensing
Vibration		10 G (20Hz to 200Hz XYZ)
Shock		80 G
Regulations		CE (EN61000-6-2, EN61000-6-3), FCC Part 15 class B, RoHS/WEEE
Power	12-pin PoCXP	12V to 24V DC ± 10%. 7.8W typical @ 12V 24V DC ± 2V. 7.8W typical @ 24V
Lens mount		C-mount
Dimensions (H x W x L)		62 mm x 62 mm x 55.5 mm
Weight		215 g
Ordering Information		
SP-5000M-CXP4		Monochrome camera with four-channel CoaXPress
SP-5000C-CXP4		Color camera with four-channel CoaXPress

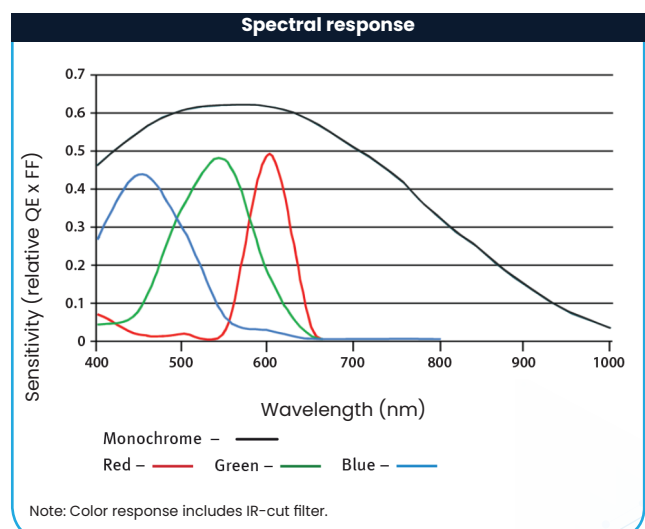
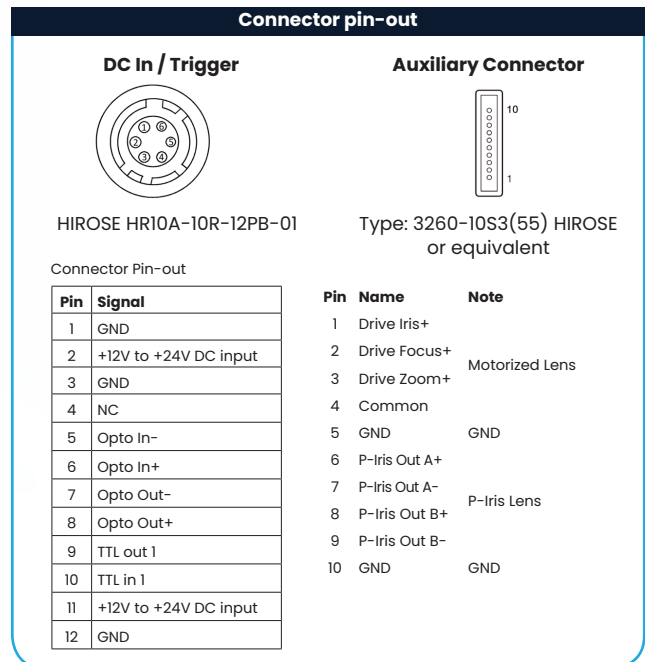
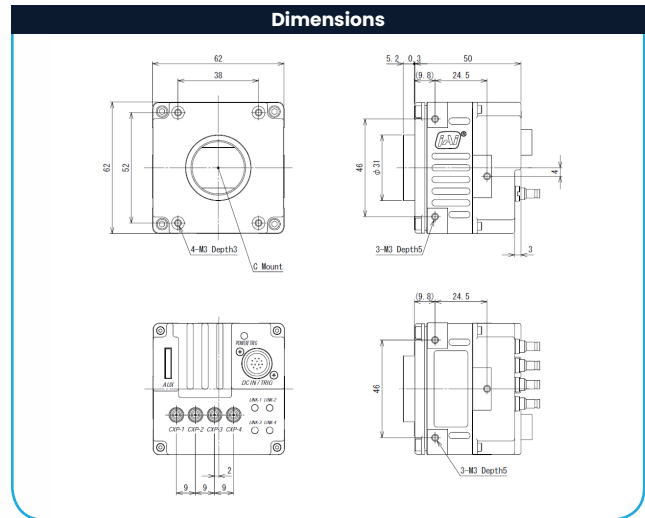

*Traditional SNR is based on random noise in a single frame, where EMVA SNR measurements consider more comprehensive noise sources and variance over time. For a more complete description, see the manual.
 †Reduced performance may occur when operating outside the standard range of -5°C to +45°C

Product Highlights

- Large format 5 MP CMOS imager (global shutter)
- Up to 253 fps at full resolution
- 5.0 μm square pixels in a 5:4 aspect ratio
- 60 dB linear dynamic range with up to 84 dB piece-wise HDR modes
- Analog and digital gain control for less quantized noise in low-light situations
- Exposure control from 10 μs (1/100,000) to 8 seconds in 1 μs steps
- 2X binning for increased sensitivity (monochrome only)
- ROI modes for flexible readout, windowing, or increasing frame rate
- Monochrome or color models with built-in color interpolation on color model
- 8/10/12-bit digital output over four-channel CoaXPress interface
- Accepts power via CoaXPress or separate 12-pin connector
- C-mount lens mount
- Automatic Level Control (ALC) for dynamic lighting conditions
- Programmable P-iris lens control or 3-axis control for operation of motorized lenses, pan/tilt heads, or other analog accessories

Additional Product Images



Company and product names mentioned in this datasheet are trademarks or registered trademarks of their respective owners.

JAI A-S and Machine Vision Direct, LLC Cannot be held responsible for any technical or typographical errors and reserves the right to make changes to products and documentation without prior notice