

# SW-8000Q-10GE

## Technical Datasheet

Custom



See the possibilities



## Apex Series



The Sweep+ Series comprises 3-sensor R-G-B and 4-sensor R-G-B-NIR or R-G-B-SWIR line scan cameras for industrial machine vision applications.

They features state-off-the-art prism technology providing the best possible performance, precision, and versatility for line scan imaging in continuous production flows.

### Specification Highlights

<b>SENSOR:</b>	Custom	<b>SHUTTER:</b>	Global Shutter
<b>FORMAT:</b>	30.72 mm	<b>FRAME RATE:</b>	36 kHz
<b>PIXEL SIZE:</b>	3.75 x 5.78 $\mu\text{m}$	<b>INTERFACE:</b>	10 Gbps GigE Vision
<b>LENS MOUNT:</b>	F-Mount	<b>RESOLUTION MP:</b>	N/A MP
<b>SPECTRUM:</b>	Multispectral (4-Bands R-G-B + NIR)	<b>RESOLUTION WxH:</b>	8192 x 1 px

Specifications		SW-8000Q-10GE
Scanning system	4 high-speed CMOS line sensors, prism-mounted	
Active pixels	4 x 8192 pixels (R, G, B, NIR)	
Line rate (full width)	Up to 36 kHz (variable) for 8-bit RGB + NIR 37 kHz possible with YUV compression	
Sensor width	30.72 mm	
Pixel size	3.75 $\mu\text{m}$ x 5.78 $\mu\text{m}$	
Ethernet speeds	10GBASE-T, 5GBASE-T, 2.5GBASE-T, 1000BASE-T Full backwards compatibility	
Video output	Single stream: RGBa8 Two streams: RGB8, RGB10VPacked, RGB10p32, YUV422_8_UVYV, YUV422_8 (visible) Mono8, Mono10Packed (NIR)	
Object illuminance (min.)	214.5 lx @ 7800 K (Gain 30 dB, 525 $\mu\text{s}$ exp, 50% video, f/2.8)	
Responsivity	RGB: 41 DN/nJ/cm <sup>2</sup> @ 550 nm (G channel) NIR: 24 DN/nJ/cm <sup>2</sup> @ 800 nm (10-bit, 0 dB gain)	
S/N ratio	>53 dB on green, 10-bit with 0 dB gain >55 dB on NIR, 10-bit with 0 dB gain	
Inputs (Trigger)	1 Opto In + 1 TTL via 12-pin, 2 TTL via 10-pin, Pulse Generator (4), NAND Out (2), Action (4), User Out (4)	
Outputs	2 TTL via 12-pin, 2 TTL via 10-pin	
Gain	Digital Master: 0 to +30 dB, R/B/NIR: -4 to +12 dB Digital Individual: 0 to +36 dB	
White balance	Manual/one-push auto by gain or exposure (4000K - 9000K) 3 Presets (5000K, 6500K, 7500K)	
Gamma	0.45 to 1.0 (9 steps) or 257-point LUT	
Image processing	PRNU/DSNU, black level, flat shading and color shading correction, chromatic aberration adjustment, horizontal mirroring, noise filtering	
Color space conversion	RGB or RGBa8 to HSI, XYZ (CIE), sRGB, Adobe RGB, or User Custom RGB	
Exposure modes	No shutter, timed, and trigger width control	
Electronic shutter	3 $\mu\text{s}$ to 27778 $\mu\text{s}$ in 1 $\mu\text{s}$ increments at 36 kHz. Exposure time can be longer at slower line rates.	
Pulse width control	1.8 $\mu\text{s}$ to -1 sec	
Time synchronization	Support for Precision Time Protocol (IEEE 1588)	
Lens mount	Nikon F-mount or M52 mount (46.5 mm flange back for both mounts)	
Operating temp. (ambient)	-5°C to +45°C (20 to 80% non-condensing)	
Storage temp. (ambient)	-25°C to +60°C (20 to 80% non condensing)	
Vibration	3G (20 Hz to 200 Hz, XYZ directions)	
Shock	50G	
Regulations	CE (EN61000-6-2, EN61000-6-3) FCC Part 15 Class B, RoHS/WEEE	
Power	12-pin PoE	+10V to +25V DC. 19.3 W typical @ 12V Not supported.
Dimensions (H x W x L)	(without connector and lens mount protrusions) 90 mm x 90 mm x 120 mm	
Weight	980 g	
Ordering Information		
SW-8000Q-10GE-F	4-CMOS prism line scan camera with F-mount	
SW-8000Q-10GE-M52	4-CMOS prism line scan camera with M52 mount	

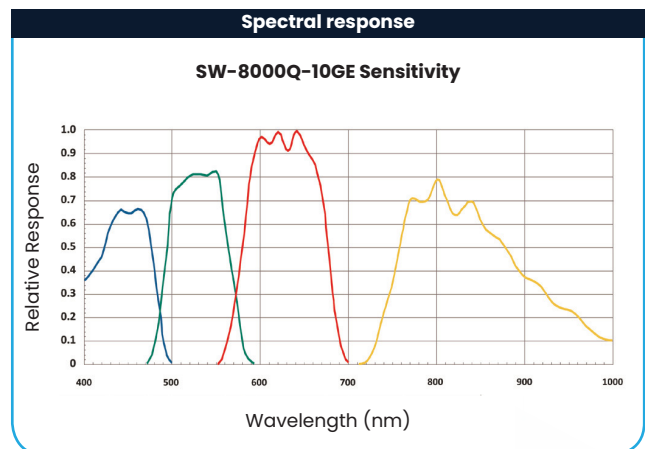
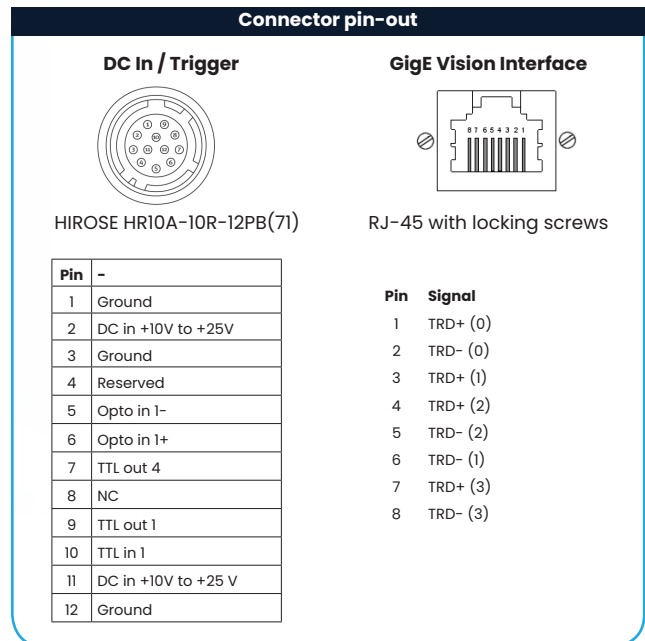
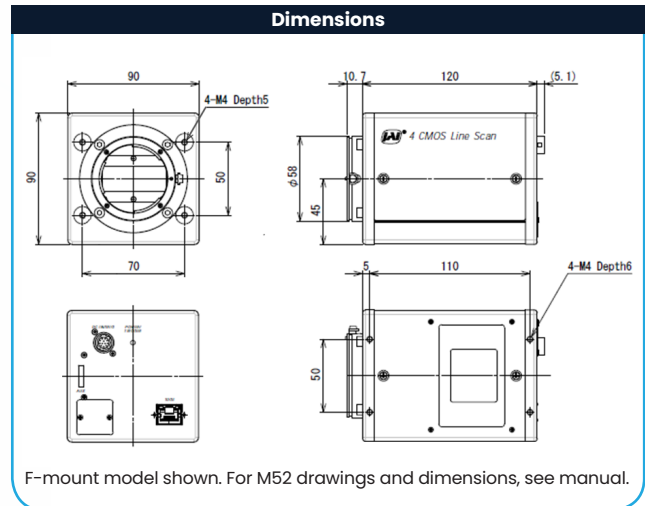

## Product Highlights

- 4 x 8192 pixel prism-based 10GBASE-T line scan camera
- Max. line rate of 36 kHz for RGB8 + NIR dual-stream output
- Prism technology for superior color quality and alignment of visible + NIR channels
- Backwards compatible to NBASE-T (5GBASE-T/2.5GBASE-T) and standard GigE (1000BASE-T)
- New "State of the art" CMOS sensors with 3.75 x 5.78  $\mu\text{m}$  pixels
- Supports vertical dual-line binning, 2x horizontal binning, or both
- ROI capability can increase line rate by reducing number of pixels per line
- Flat field correction and color shading correction
- HSI and XYZ color space conversion
- Supports direct connection to rotary encoders plus large variety of trigger options
- GigE Vision 2.0 interface with choice of single-stream (RGBa8) or dual-stream output
- Color output can be 24/30/32-bit RGB or 8-bit YUV format
- Excellent shock and vibration resistance

## Additional Product Images



Company and product names mentioned in this datasheet are trademarks or registered trademarks of their respective owners.

JAI A-S and Machine Vision Direct, LLC Cannot be held responsible for any technical or typographical errors and reserves the right to make changes to products and documentation without prior notice